

CATALOGUE

Commercial/Professional Audio





(주) 파스컴
PASCOM
031-733-1060



(주)파스컴은 PA시스템, 앰프, 스피커를 공급하는 세계에서 가장 주된 공급자 중 하나이며, 제품을 국내 50여 개의 대리점에 유통하고 러시아, 이집트, 두바이, 유럽, 그리고 아시아로 수출하여 세계적으로 성장하는 회사가 되었습니다. 다년 간 앰프, 스피커, PA시스템을 제조함에 있어 탁월한 기술력을 겸비해왔으며, 끊임없이 개선하여 제품 제조에 관한 전문성으로 사실상 모든 PA시스템 산업 분야에 그 명성을 유지하고 있습니다. 앞으로도 파스컴은 오랜 기간 쌓아온 기술과 노하우를 바탕으로 고객 감동 실현에 최선을 다하겠습니다.

We PASCOM is one of the world's most important supplier for amplifiers, speakers, and PA system. Our products have been distributed to about 50 agencies in Korea and exported to Russia, Egypt, Dubai, Europe, and Asia. We've had excellent technology in manufacturing PA system equipment, maintaining its reputation in PA system industry. Based on the technology and know-how that we've built for a long time, we'll do our best to satisfy the customers.

주식회사 파스컴
대표이사 이영수



CONTENTS

01 포터블 앰프 PORTABLE AMPLIFIER

- 4 APOLLON-1002/1502/3002
- 5 APOLLON-1004
- 5 MUSE-602
- 6 NYX-1004/1204/2004/3004
- 7 S-30M/60M
- 7 SMA-1202A
- 8 PMA-Series
- 9 Zome(M)-Series
- 10 PANDORA(D)-Series
- 11 PCR-70D/130D
- 12 WA-102
- 12 APT-60L
- 13 EWA-Series
- 14 EWA-16M/32M
- 14 EWA-32PT
- 15 MP3-16/32
- 15 DMS-8RM

02 일원화 시스템 UNIFIED PA SYSTEM

- 18 EDC-1SW
- 18 EDC-1000
- 19 EDS-1000
- 19 ERI-1000
- 20 ERM-1000
- 20 ESS-2016M
- 21 ESS-2016S

03 다원화 시스템 DIVERSIFIED PA SYSTEM

- 24 DMS-8SW
- 24 DMS-8SV
- 25 DMS-8MC
- 26 DMS-8ESC
- 26 DMS-8PS
- 27 DMS-8RIM

04 디지털 RX-TX PA 시스템

DIGITAL RX-TX PA SYSTEM

- 30 SW-9600
- 30 SW-9601
- 31 DSV-9600
- 31 DCV-9600
- 32 DMC-9600SE
- 32 DPS-9600
- 33 DSC-9600
- 33 DRG-9600
- 34 DEI-9600
- 34 PRX-3100
- 35 DRA-9600
- 35 DRI-9600

05 아날로그 시스템 ANALOG PA SYSTEM

- 38 PX-9600
- 38 PS-9616I
- 39 RG-9600

39 ES-9600

40 ESS-9642

40 PS-9616

41 RM-9616

41 RE-9600

06 앰프 AMPLIFIER

- 44 DPA-300/400/500/600
- 45 PA-9612/9624/9636/9648

07 공통장비 COMMON UNIT

- 48 AD-9600
- 48 BK-9610/9620/9630
- 49 BC-9600
- 49 BC-9660
- 50 EM-9600V
- 50 PD-9600
- 51 PDC-9600
- 51 PF-9600
- 52 PG-9600
- 52 PMP-3100
- 53 PP-9600
- 53 PP-9620
- 54 PEX-4
- 54 TB-9616/9632

08 단락보호기기 SHORT CIRCUIT PROTECTION

- 56 PLC-9616
- 56 PLF-9605
- 57 PLF-105
- 57 ST-03/05/08
- 58 ST-051S/054S
- 58 STU-051S/054S

09 음원공급장치 SOURCES

- 60 CDR-3100
- 60 MCD-9600A
- 61 DRT-9600
- 61 DPT-9602
- 62 DTP-9600
- 62 DC-9600S
- 63 PCS-3100
- 63 SV-9600
- 64 ESA-1000
- 64 PJS-2030

10 무선마이크 WIRELESS SYSTEM

- 66 PWR-951
- 66 PWR-952
- 67 PWR-962
- 67 H-50
- 67 B-50
- 67 HS-12
- 68 WAD-900
- 68 PWR-AT
- 68 PWR-ATD

11 SR 시스템 SR SYSTEM

- 70 DM32PRO
- 70 MX-1204PS
- 71 DSP48PRO
- 71 FBS4
- 72 PA-EQ131/231
- 72 SP-9600
- 73 DA-200/300/400/600
- 74 PN2S/4S/6S
- 75 PN14S
- 75 PN88S

12 마이크 / 스피커 / 액세서리

MIC / SPEAKERS & ACCESSORIES

- 78 DM-980/990
- 78 PRM-01
- 78 MS-1D
- 78 MS-1F
- 79 HY-08/10/12/15
- 79 F-08/10/12/15
- 80 FS-200
- 80 SR-ST1
- 80 SR-SWB
- 81 KWS-310(B/W)
- 81 KFS-40/60/80(B/W)
- 82 AS-01A
- 82 AS-101/102/103
- 83 AS-03A/06A/10A
- 83 AS-503/506
- 84 AS-03P
- 84 HS-20/30/50
- 85 KWS-03/10
- 85 KWS-03R/10R
- 86 PCS-10/20/30/40
- 86 CS-410/420/430/440
- 87 PCU-10/20/30/40
- 87 CS-710/720/730/740
- 88 PRS-30
- 88 AAS-1000

13 랙캐비닛 RACK

- 86 AR (Aluminum)
- 86 CR (Steel)

14 어플리케이션 APPLICATION

PORTABLE AMPLIFIER

Table Type

APOLLON-1002/1502/3002	Digital Stereo Karaoke Amplifier	4
APOLLON-1004	Professional Digital Echo Karaoke Amplifier	5
MUSE-602	Karaoke Amplifier	5
NYX-804/1204/2004/3004	4 Zone Mixing Amplifier	6
S-30M/60M	Mixing Amplifier	7
SMA-1202A	2CH Mixing Amplifier	7
PMA-120M/240M/360M	Public Address Mixing Amplifier	8
ZONE-120M/240M/360M/480M/600M	A.T.T 6 Zone Mixing Amplifier	9
PANDORA-1D/2D/3D	Multi PA Combination Amplifier	10
PCR-70D / 130D	Multi Combination Amplifier	11

Wall Type

WA-102	2 Zone Mixing Amplifier	12
APT-60L	Emergency Wall Amplifier	12
EWA-60/120/240/360/480/600T	Emergency Wall Amplifier	13
EWA-16M / 32M	Channel Expanding BD for EWA	14
EWA-16PT / 32PT	Program Timer Module For EWA	14
MP3-16 / 32	MP3 Module for EWA	15
DMS-8RM	Digital Remote Controller	15

DIGITAL STEREO KARAOKE AMPLIFIER

APOLLON-1002/1502/3002



SPECIFICATION	APOLLON-1002	APOLLON-1502	APOLLON-3002
RATED POWER	100W + 100W	150W + 150W	300W + 300W
OUTPUT IMPEDANCE		4Ω / 8Ω	
FREQUENCY RESPONSE		20Hz-20KHz	
S/N		90dB	
SEPARATION		48dB	
T.H.D		< 0.2% at 1KHz	
POWER SOURCE		AC 220V / 50~60Hz	
WEIGHT	6.55Kg	7.35Kg	9.3Kg
DIMENSION		420(W) × 132(H) × 330(D) mm	

- USB, SD Card 플레이 기능
- 하울링 방지 기능
- 디지털 에코 시스템 기능
- 고음,중음,저음 조절 기능
- 마이크 & 음악 볼륨 조절 기능
- 기록 및 외부연결을 위한 라인
- 라디에이터 팬을 사용한 방열 강화로 장시간 안정적 운영 가능.

- USB, SD card playing
- Howling prevention
- Digital ecosystem function
- Treble, midrange, and bass adjustments
- Microphone and music volume control
- Line-in for recording and external connection
- Radiator fan for enhanced heat dissipation, ensuring long-term, stable operation

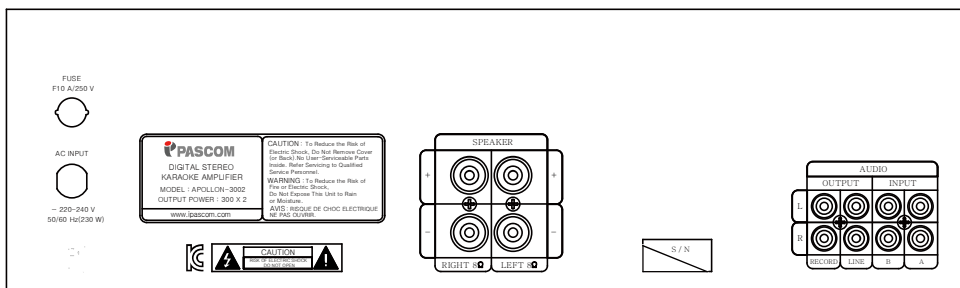

PROFESSIONAL DIGITAL ECHO KARAOKE AMPLIFIER

APOLLON-1004

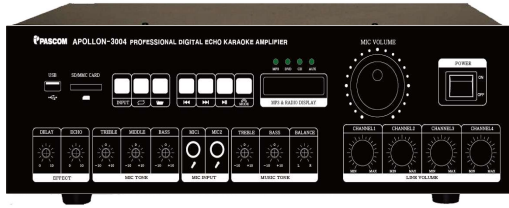

SPECIFICATION	
RATED POWER	100W + 100W + 100W + 100W
OUTPUT IMPEDANCE	4Ω / 8Ω
FREQUENCY RESPONSE	20Hz ~ 20KHz
S/N	90dB
SEPARATION	48dB
T.H.D	≤0.21% at 1KHz
POWER SOURCE	AC 220V / 50~60Hz
WEIGHT	7.35kg
DIMENSION	420(W) × 132(H) × 330(D) mm

- 4채널 출력 및 개별 볼륨 제어 기능
- USB, SD Card 플레이 기능
- Delay Time Control 기능
- 디지털 에코 시스템 기능
- 고음,중음,저음 조절 기능
- 마이크 & 음악 볼륨 조절 기능
- 기록 및 외부연결을 위한 라인
- 4-channel output and individual volume control
- USB and SD card playback
- Delay Time Control
- Digital Ecosystem
- Treble, midrange, and bass control
- Microphone and music volume control
- Line-in for recording and external connection

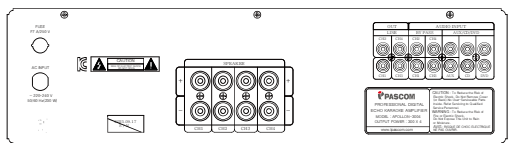

KARAOKE AMPLIFIER

MUSE-602



SPECIFICATION	
RATED POWER	300W + 300W (4Ω)
MIC INPUT	5 (front×3, rear×2)
VIDEO INPUT	4(RCA)
VIDEO OUTPUT	2(RCA)
AUDIO INPUT	4(RCA)
AUDIO OUTPUT	2(RCA)
S/N	≥90dB
T.H.D	≤0.1%
AUDIO SENSITIVITY	200mV
IMPEDANCE	1.5 KΩ
FREQUENCY RESPONSE	20Hz-20KHz, -1dB
KEY CONTROL	±7 steps
POWER SOURCE	AC 220V / 60Hz
WEIGHT	11kg
DIMENSION	430(W) × 160(H) × 360(D) mm

- USB, SD, MMC 카드 플레이 및 레코딩 기능
- 조작이 편리하고 인터페이스 조절 가능
- 고음, 중음, 저음 조절 기능
- 소스 입력 기능 : DVD/VCR/DCG(AUX)/BGM(MP3)
- MUTE 기능 : 음원 출력 중 마이크 사용 시 음원 감소
- VOD 시스템 점수 계산을 위한 음악 모드
- 기록 및 외부연결을 위한 라인
- USB, SD, MMC card playing & recording
- Easy use and interface control
- Tone controller for BASS, MID, TREBLE
- Sources support DVD/VCR/DCG(AUX)/BGM(MP3)
- MUTE function : music becomes smaller when using mic
- Scoring mode for VOD system
- Lines for connecting external inputs

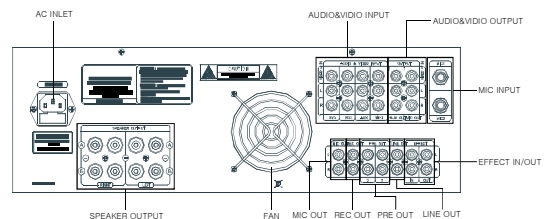

MIXING AMPLIFIER

NYX-804/1204/2004/3004



SPECIFICATION	NYX-804	NYX-1204	NYX-2004	NYX-3004
RATED POWER	80W	120W	200W	300W
OUTPUT IMPEDANCE	4Ω / 16Ω /70V/100V			
4 ZONE OUTPUT	100V			
FREQUENCY RESPONSE	40Hz-20KHz ± 2dB			
SENSITIVITY	AUX : -10dB / MIC : -52dB			
S/N	≥ 80dB			
T . H . D	< 1% at 1/3 Voltage			
POWER SOURCE	AC 220V ~ 204V / 50~60Hz			
DIMENSION	350(W) × 63(H) × 300(D) mm			

- XLR 오디오 콤보 잭 입력 2개, 마이크 / 라인 선택 가능
- AUX 입력 1개, 출력 1개 적용
- 4채널 개별 출력 볼륨 제어 기능
- 고음,중음,저음 조절 기능
- 마이크 볼륨 조절 및 Mute 기능
- Bluetooth, FM Radio, USB, SD Card 플레이 가능
- 단락, 과부하를 위한 보호회로 내장
- True Volor LCD 화면 장착

- 2 XLR audio combo jack inputs, mic/line selectable
- 1 AUX input, 1 output
- 4-channel individual output volume control function
- Treble, midrange, and bass adjustments
- Microphone volume control and mute function
- Bluetooth, FM Radio, USB, SD Card play functions
- Built-in protection circuit for short circuit and overload
- Equipped with True Volor LCD screen

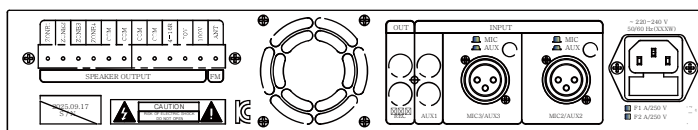

MIXING AMPLIFIER

S-30M/60M



SPECIFICATION	S-30M	S-60M
RATED POWER	30W	60W
INPUT SENSITIVITY	MIC1~2 : 1mV AUX1~2 : 100mV	
FREQUENCY RESPONSE	MIC1~2 : 63Hz~15kHz AUX1~2 : 50Hz~18kHz	
S/N	MIC1~2 : ≥60dB AUX1~2 : ≥70dB	
T.H.D	≤0.5%	
POWER SOURCE	AC 220V / 60Hz, DC 12V	
POWER CONSUMPTION	33W	62W
WEIGHT	4.1kg	4.9kg
DIMENSION	306(W) × 82(H) × 245(D) mm	

- 3.5" 잭을 전면에 내장하여 PC 또는 스마트 음원 연결 가능
- 음색 조절을 위한 2밴드 톤 컨트롤 내장
- 온도 감지 보호 회로 내장
- MIC1에 뮤트 기능이 있어 방송 우선 및 조절 가능
- Able to connect PC or smart devices by 3.5" jack in front panel
- Controller of 2 bands for tone adjustment
- Protection circuit for overheat is embedded
- Mute function for MIC1

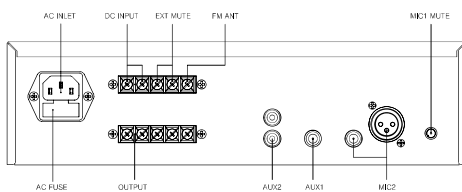

2CH MIXING AMPLIFIER

SMA-1202A



SPECIFICATION	
RATED POWER	120W
INPUT SENSITIVITY	MIC1~2 : 3mV / AUX1~2 : 150mV
FREQUENCY RESPONSE	MIC1~2 : 120Hz~15kHz / AUX1~2 : 80Hz~18kHz
S/N	MIC1~2 : ≥60dB / AUX1~2 : ≥70dB
T.H.D	≤0.5%
POWER SOURCE	AC 220V / 60Hz
POWER CONSUMPTION	35W
WEIGHT	6.1kg
DIMENSION	306(W) × 82(H) × 245(D) mm

- CLASS-D 앰프를 내장하여 높은 음질 구현
- ATT 기능이 내장되어 구역별 별도의 음량으로 방송 가능
- 3.5" 잭을 전면에 내장하여 PC 또는 스마트 음원 연결 가능
- 음색 조절을 위한 2밴드 톤 컨트롤 내장
- 온도 감지 보호 회로 내장
- MIC1에 뮤트 기능이 있어 방송 우선 및 조절 가능
- Made with CLASS-D amp for high performance
- ATT enables individual volume control for each zone
- Able to connect PC or smart devices by 3.5" jack in front panel
- Controller of 2 bands for tone adjustment
- Protection circuit for overheat is embedded
- Mute function for MIC1

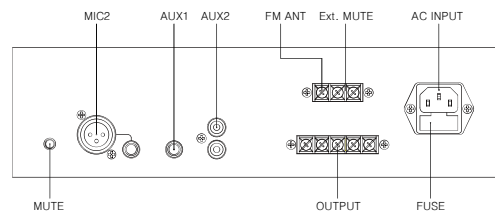

PUBLIC ADDRESS MIXING AMPLIFIER

PMA-60M/120M/240M



SPECIFICATION	PMA-60M	PMA-120M	PMA-240M
RATED POWER	60W	120W	240W
INPUT SENSITIVITY	MIC1~5 : 1mV CH1~2(AUX/MIC) : 15mV / 150mV CH4 : 500mV		
FREQUENCY RESPONSE	MIC1~5 : 63Hz~18kHz CH1~3 : 50Hz~18kHz CH4 : 50Hz~20kHz SIREN : 630Hz		
S/N	MIC : ≥60dB CH : ≥70dB		
T.H.D	MIC : ≤0.3% CH : ≤0.2%		
POWER SOURCE	AC 220V, 60Hz		
WEIGHT	9.3kg		12kg
DIMENSION	482(W) × 88(H) × 340(D) mm		482(W) × 132(H) × 340(D) mm

- 5개의 개별 스피커 셀렉터와 한 개의 전체 스위치가 있어 필요한 구역에 선택 방송 가능
- 7밴드 이퀄라이저로 음색 조절 가능
- 4음계 차임이 있어 방송 전 후로 사용 가능
- 온도 감지 보호 회로를 내장하여 과부하로 인해 규정 온도 이상이 될 경우 자동으로 출력을 OFF 시킴
- MP3 플레이 및 FM 튜너가 내장되어 있어 BGM 방송 시 편리
- 5 individual zone selectors and 1 all zone selector
- 7 band equalizer for tune adjustment
- Able to use 4 tone chime for start and end of broadcast
- Thermister on main heat sink prevents overheat and overload
- Easy to broadcast BGM by MP3 player and FM tuner

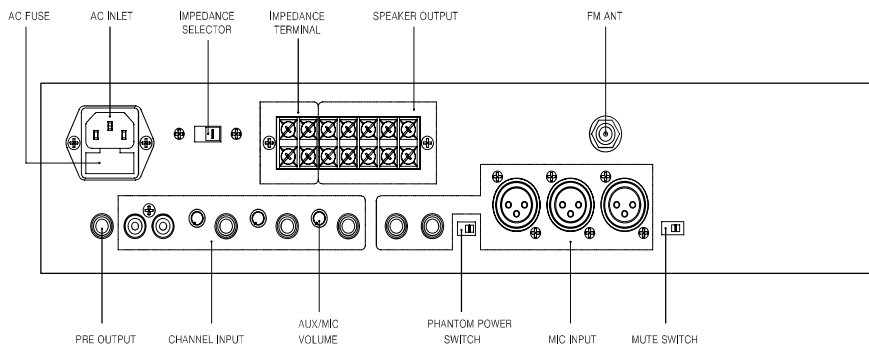

ATT 6 ZONE MIXING AMPLIFIER

ZONE-120M/240M/360M/480M/600M



SPECIFICATION	ZONE-120M	ZONE-240M	ZONE-360M	ZONE-480M	ZONE-600M
RATED POWER	120W	240W	360W	480W	600W
INPUT SENSITIVITY	MIC1~4 : -50dB LINE1~4 : -10dB LINE5~6 : -14dB PC IN(ST) : -10dB				
FREQUENCY RESPONSE	MIC1~4 : 100Hz~14kHz LINE1~4 : 80Hz~16kHz LINE5~6 : 80Hz~16kHz SIREN : 630Hz				
S/N	MIC : ≥55dB LINE : ≥70dB				
T.H.D	≤1%				
POWER SOURCE	AC 220V / 60Hz, DC 24V				
POWER CONSUMPTION	185W	273W	411W	550W	610W
WEIGHT	18kg	19kg	21kg	21kg	22kg
DIMENSION	482(W) × 132(H) × 340(D) mm				

- 6개의 개별 스피커 셀렉터와 한 개의 전체 스위치가 있어 필요한 구역에 선택 방송 가능
- 각 개별 셀렉터마다 출력 조정(ATT) 가능
- PRIORITY 기능이 내장되어 원하는 입력을 우선 순위로 설정 가능
- 4음계 상향/하향 차임 버튼이 있으며 외부 연결 단자가 있어 원거리에서도 사용 가능
- 화재수신반(R형, P형)과 연동하여 미리 녹음된 방송 출력 및 비상 방송 출력 가능
- 원거리에서 전원 ON/OFF 가능
- SD카드 또는 USB에 저장된 MP3 파일 재생 가능
- 장비의 출력을 USB에 녹음 및 재생 가능
- 전원 ON 상태에서 배터리를 자동 충전하며 정전 시 배터리로 동작

- 6 individual zone selector and 1 all zone selector
- ATT enables to control the volume for each zone
- Priority broadcast function
- Able to use 4 tone of ascending / descending chime for start and end of broadcast (remote control available)
- Able to broadcast recorded file or emergency announcement by connecting with fire system
- Able to turn ON/OFF the power remotely
- Playing files stored in SD card or USB
- Able to record and play it's output into USB
- Charging the connected battery when power is on
- Operating by battery in blackout

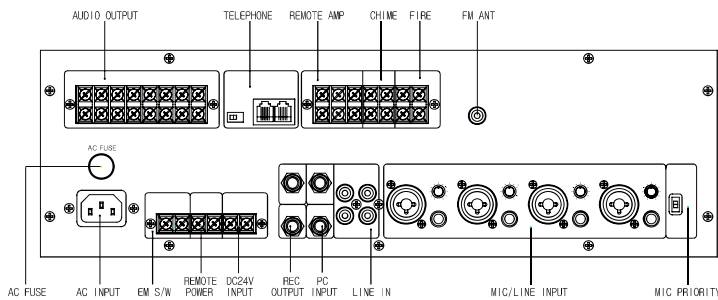

MULTI PA COMBINATION AMPLIFIER

PANDORA-1D/2D/3D



SPECIFICATION	PANDORA-1D	PANDORA-2D	PANDORA-3D
RATED POWER	120W	240W	360W
INPUT SENSITIVITY / IMPEDANCE	MIC1 : 2.7mV / 2.4kΩ, UNBAL MIC2~5 : 2.7mV / 2.4kΩ, BAL AUX1~2 : 300mV / 600Ω, UNBAL REMOTE : 1V/600Ω, BAL		
OUTPUT VOLTAGE / IMPEDANCE	70V/42Ω 100V/83Ω	70V/21Ω 100V/42Ω	70V/14Ω 100V/28Ω
FREQUENCY RESPONSE	80Hz~18kHz		
S/N	≥65dB		
T.H.D	≤1%		
POWER SOURCE	AC 220V, 60Hz		
POWER CONSUMPTION	180W	360W	540W
WEIGHT	16kg	23kg	30kg
DIMENSION	420(W) × 266(H) × 340(D) mm		

- 마이크 전용 입력 5개와 보조 입력 2개로 구성
- 10개의 개별 스피커 셀렉터와 1개의 ALL 셀렉터가 있어 필요한 구역을 선택하여 방송 가능
- 고감도 디지털 튜너를 내장하여 선명한 방송 청취 가능
- FM 30개, AM 30개 주파수 메모리 기능이 있어 편리하게 사용 가능
- 2음계 차임과 4음계 차임이 있어 방송 전 사용 가능
- USB 저장장치 내 MP3 파일과 AVI 파일 재생 가능
- DVD 매커니즘 채택으로 다양한 오디오 및 영상 매체 재생 가능
- NTSC, PAL 방식 구현이 가능하며 다양한 출력 단자 채용 (컴포넌트, 콤포지트, S-VIDEO, OPTICAL, 광단자, PC VGA)
- 고감도 7밴드 이퀄라이저
- 테이프 A면과 B면을 반복 재생하는 오토리버스 기능과 더빙 및 릴레이 플레이 기능을 가진 카세트 더블 데크 장착
- 내장된 모니터 스피커를 통해 출력 신호를 쉽게 확인 가능
- 5 inputs of microphone and 2 inputs of AUX
- 10 individual zone selectors and 1 all zone selector
- High sensitivity digital tuner is embedded for clear listening
- Able to memorize frequencies (FM×30, AM×30)
- Able to use 2 tone for 4 tone chime for start of broadcast
- MP3 and AVI file play stored in USB
- DVD mechanism enables playing various formats of audio and video
- Various terminals (Component, Composite, S-VIDEO, OPTICAL, PC VGA)
- 7 band equalizer
- Cassette double deck for auto-reverse, dubbing, and relay play
- Easy to check output level by a monitor speaker

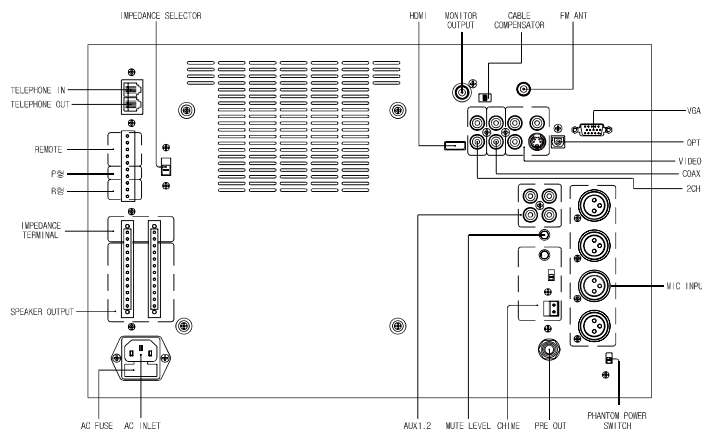

MULTI COMBINATION AMPLIFIER

PCR-70D / 130D



SPECIFICATION	PCR-70D	PCR-130D
RATED POWER	70W	130W
INPUT SENSITIVITY INPEDANCE	MIC1 : 1mV / 2.4KΩ / UNBAL MIC2~3 : 1mV / 2.4KΩ / BAL AUX : 100mV / 10KΩ / UNBAL Paging : 310mV / 600Ω / UNBAL	
FREQUENCY RESPONSE	80Hz ~ 18KHz (+1dB/-3dB)	
T.H.D	≤1%	
S/N	≥75%	
TONE CONTROL	100Hz / 10KHz	
TUNING RANGE	FM : 87.5MHz ~ 108MHz AM : 522KHz ~ 161KHz	
POWER SOURCE	AC 220V / 60Hz	
POWER CONSUMPTION	160W	270W
WEIGHT	10kg	14kg
DIMENSION	420(W) × 132(H) × 350(D) mm	

- 정격출력 : 70W / 130W
- DVD / MP3 / 오디오 CD 플레이 기능
- 입력 : MIC 1~3 & AUX & CD & 마이크 JACK 이 PL55, XLR 2가지로 설계되어 사용이 편리
- 2음, 4음 차임 기능 : 도, 미 2계음 / 도, 미, 솔, 도 4계음 차임 기능
- USB 내에 저장되어 있는 MP3, AVI 파일 재생 기능
- 사진(JPG) 및 동영상(AVI) 파일 재생 기능
- 고감도 디지털 튜너 및 메모리 기능
- 스피커 셀렉터 : 2개의 스피커 셀렉터로 구역별 선택 방송 가능
- MUTE 기능 : MIC 1 과 차임 신호에 의하여 다른 채널의 신호를 통제할 수 있고 뒷면의 세미 볼륨으로 MUTE 레벨 조절 가능
- 텔레폰 페이징 기능

- Rated Power : 70W / 130W
- DVD / MP3 / Audio CD playing function
- Input : MIC 1~3 & AUX & CD Two types of jack for microphone : PL55, XLR
- 2 tone, 4 tone chime : C, E / C, E, G, C
- MP3, AVI stored in USB can be played
- JPG and AVI files can be played
- High sensitivity digital tuner with memory function
- 2 Speaker selectors to broadcast by zone
- MUTE function : MIC 1 and chime can control other channels' signal and can adjust mute level by controller at the rear
- Telephone paging function for remote broadcasting

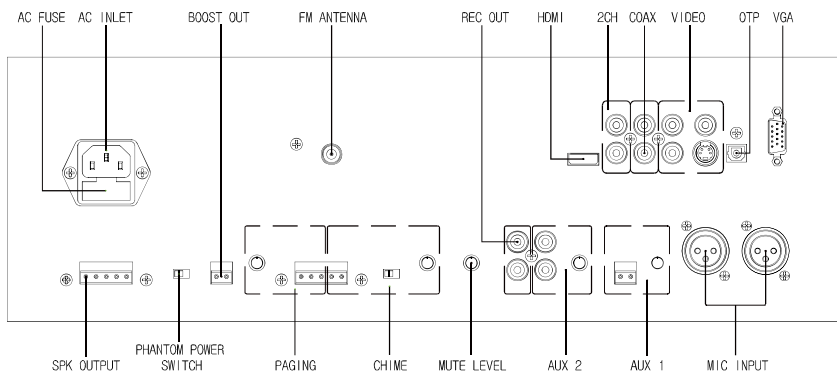

2 ZONE MIXING AMPLIFIER

WA-102



SPECIFICATION	
RATED POWER	100W / 4Ω x 2 Zone
INPUT SENSITIVITY	MIC1~2 : -50dB AUX1~2 : -20dB
FREQUENCY RESPONSE	MIC1~2 : 80Hz~18kHz AUX1~2 : 80Hz~18kHz
S/N	MIC1~2 : ≥60dB AUX1~2 : ≥70dB
T.H.D	≤1%
POWER SOURCE	AC 220V / 60Hz
WEIGHT	3.2kg
DIMENSION	310(W) × 222(H) × 95(D) mm

- SD Card / USB를 통한 MP3 재생 기능
- FM 라디오 수신 방송 기능
- MIC1/2, AUX 1/2 를 통한 다양한 멀티미디어 기기 연결, 방송 가능
- 2.4G 무선마이크 송수신기를 적용하여 혼선 없는 마이크 방송 가능
- Zone 별로 독립된 음량조절기를 통한 Zone별 음량 조절 가능
- 100W/4Ω 2채널 D-CLASS AMP 사용
- MP3 playback via SD Card/USB
- FM radio reception broadcast function
- Connects to various multimedia devices and broadcasts via MIC1/2 and AUX 1/2
- 2.4G wireless mark transmitter and receiver enable interference-free microphone broadcasting
- Zone-specific volume control is possible through independent volume controls for each zone.
- Uses 100W/4Ω 2-channel D-CLASS AMP

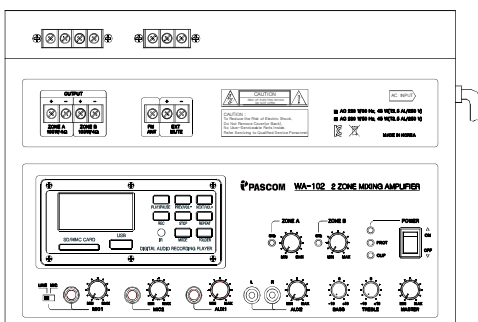

EMERGENCY WALL AMPLIFIER (ALL ONLY)

APT-60L



SPECIFICATION	
RATED OUTPUT	60W
INPUT SENSITIVITY / IMPEDANCE	MIC : 4mV / 47kΩ REMOTE : 1V / 3.3kΩ, BAL REMOTE : 100V, BAL
OUTPUT VOLTAGE / IMPEDANCE	70V / 83Ω 100V / 165Ω
FREQUENCY RESPONSE	80Hz~18KHz
T.H.D	≤1%
S/N	MIC : 60dB REMOTE : 70dB
POWER SOURCE	AC 220V, 60Hz
POWER CONSUMPTION	STANDBY : 16W / LOAD : 110W
DIMENSION	350(W) × 400(H) × 140(D) mm

- 일반방송 및 화재방송 기능 (4음계 차임이 있어 방송 전, 후 사용 가능)
- P형 화재수신기와 호환 가능
- RM-9616을 사용하여 리모트 방송 가능
- 내장된 배터리를 자동 충전하며, 정전 시 배터리로 약 10분 간 방송 가능
- 편리한 모니터링 기능
- 출력 70V, 100V 선택 가능
- Normal broadcast and emergency broadcast available (4 tone chime for start or end of broadcast)
- Contact type fire system can be connected with it
- Able to broadcast remotely by RM-9616
- Charge a battery inside and use battery in blackout about 10 mins
- Easy monitoring
- Able to select 70V or 100V

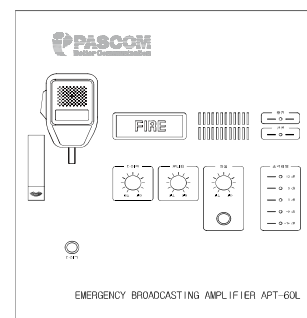

EMERGENCY WALL AMPLIFIER

EWA-60/120/240/360/480/600T



SPECIFICATION	EWA-60T	EWA-120T	EWA-240T	EWA-360T	EWA-480T	EWA-600T
RATED OUTPUT	60W	120W	240W	360W	480W	600W
INPUT SENSITIVITY / IMPEDANCE	MIC : 4mV/47kΩ, UNBAL REMOTE : 0.5V/3.3kΩ REMOTE : 100V, BAL					
OUTPUT VOLTAGE / IMPEDANCE	70V/83Ω 100V/165Ω	70V/42Ω 100V/83Ω	70V/21Ω 100V/42Ω	70V/14Ω 100V/28Ω	70V/10Ω 100V/21Ω	70V/8.2Ω 100V/16.7Ω
FREQUENCY RESPONSE	80Hz~15KHz					
T.H.D	≤1%					
S/N	MIC : ≥60dB REMOTE : ≥70dB					
POWER CONSUMPTION	STANDBY : 15W LOAD : 40W	STANDBY : 16W LOAD : 60W	STANDBY : 25W LOAD : 90W	STANDBY : 26W LOAD : 122W	STANDBY : 28W LOAD : 160W	STANDBY : 30W LOAD : 150W
POWER SOURCE	AC 220V / 60Hz / BATTERY 24V					
DIMENSION	420(W) × 560(H) × 140(D) mm			465(W) × 621(H) × 160(D) mm		

- 일반방송 및 화재방송 기능 (4음계 차임이 있어 방송 전, 후 사용 가능)
 - P형 화재수신기와 R형 화재수신기 모두 호환 가능 (R형 화재 데이터 프로토콜 12bytes 9600bps 방식)
 - DMS-8RM을 사용하여 리모트 방송 가능
 - 내장된 배터리를 자동 충전하며, 정전 시 배터리로 약 30분 간 방송 가능
 - 편리한 모니터링 기능
 - 출력 70V, 100V 선택 가능
 - 16채널 단위로 출력 채널 확장 가능
 - 단락된 채널 선로 차단 기능
- Normal broadcast and emergency broadcast available (4 tone chime for start or end of broadcast)
 - Both contact type and data type fire system can be connected with it
 - Able to broadcast remotely by DMS-8RM
 - Charge a battery inside and use battery in blackout about 30 mins
 - Easy monitoring
 - Able to select 70V or 100V
 - Able to expand output channels by 16 channels
 - Short circuit protection

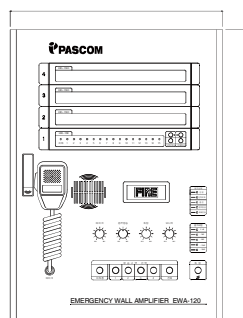

EWA-60/120

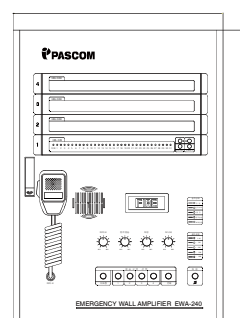

EWA-240/360/480/600

CHANNEL EXPANDING BD FOR EWA

EWA-16M/32M

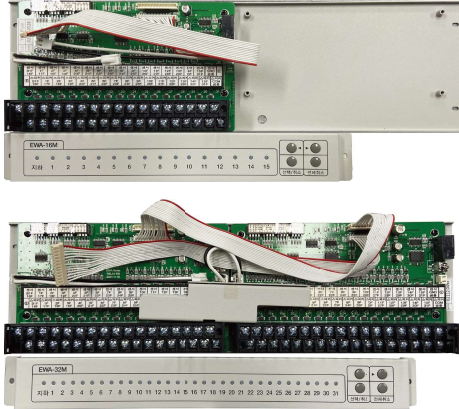

- EWA 시리즈 전용 출력 채널 확장 모듈
- EWA-60/120은 4장, EWA-240/360/480은 최대 8장까지 확장 가능
- Output channel expanding board for EWA amplifier
- Able to add maximum 4 boards for EWA-60/120, and 8 boards for EWA-240/360/480

PROGRAM TIMER MODULE FOR EWA

EWA-16PT/32PT



- EWA 시리즈 프로그램 타이머
- EWA Series Program Timer

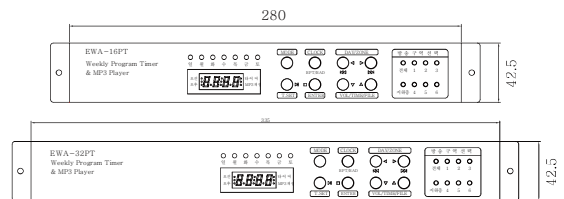
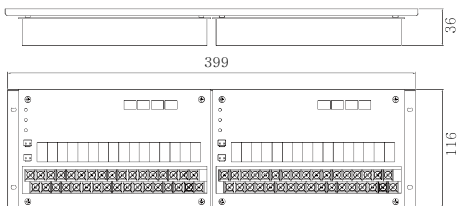

MP3 MODULE FOR EWA/APT

MP3-16/32



SPECIFICATION	MP3-16	MP3-32
RATED INPUT (@MP3, MONO)	215mV	
RATED INPUT (@AUX, MONO)	130mV	
RATED OUTPUT	1V	
T.H.D	0.3%	
WORKING VOLTAGE	DC 22V, 125mA	
DIMENSION	307(W) × 42.5(H) × 40(D) mm	362(W) × 42.5(H) × 40(D) mm

- APT-600에 장착 가능한 MP3 모듈
- FM 라디오 및 USB / SD 카드에 저장된 MP3 파일 재생
- MP3 module for APT-600
- Play FM radio and files stored in USB / SD card

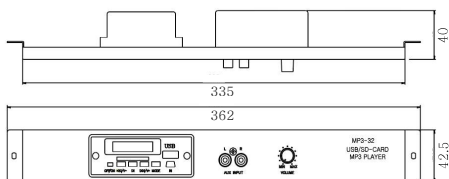

DIGITAL REMOTE CONTROLLER

DMS-8RM



SPECIFICATION	
DISPLAY	128 x 64 graphic LCD, status display LED
COMMUNICATION METHOD	CAN & RS-485
COMMUNICATION DISTANCE	1km
PROCESSOR	ATMEGA128 / 8bit
COMMUNICATION SPEED	9600bps / N / 8 / 1
POWER SOURCE	DC 24V, 180mA
WEIGHT	2kg
DIMENSION	236(W) × 50(H) × 202(D) mm

- EWA-시리즈 / Zone-시리즈 / PANDORA-시리즈 연동
- 화재 구역 표시 기능
- 화재 표기 20개 구역까지 가능
- 자체 차임 기능 및 자동 방송 복구 기능
- CAN 통신 / RS-485통신 방식
- EWA-series / Zone-series / PANDORA-series integration
- Fire zone display function
- Fire marking is possible for up to 20 zones.
- Self-chime function and automatic broadcast recovery function
- CAN communication / RS-485 communication method

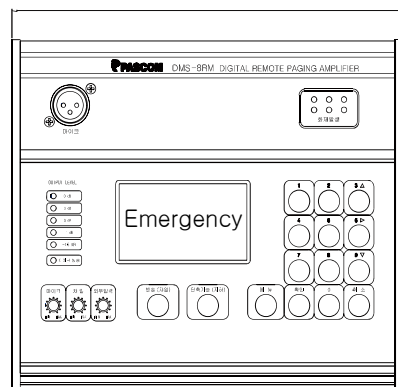
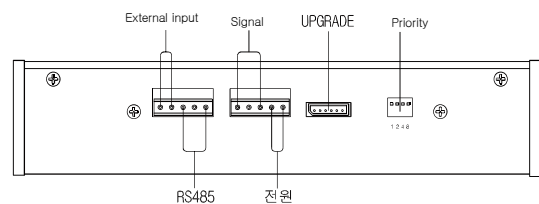

UNIFIED PA SYSTEM

EDC-1SW	EDC Series PC operating software	18
EDC-1000	Digital Emergency Main Controller	18
EDS-1000	Digital Emergency Sub Controller	19
ERI-1000	Digital Remote Interface	19
ERM-1000	Emergency Remote Amplifier	20
ESS-2016M	Digital Emergency Main Speaker Controller	20
ESS-2016S	Digital Emergency Sub Speaker Controller	21



EDC SERIES S/W

EDC-1SW

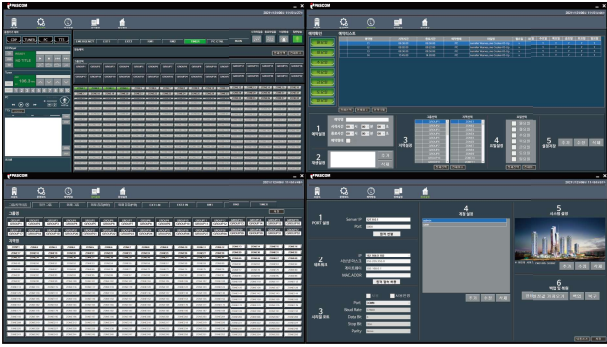

- 소스 기기 조작
Source Controller
- PC 마이크 & BGM 조작
PC MIC & BGM Controller
- 문자방송 (TTS) 조작
Text to Sound (TTS) Function
- 프리셋 설정
Preset Setting
- 입력 음원 선택
Selecting Source
- 시작 차임 & 종료 차임
Start Chime & End Chime
- 비상 방송 or 일반 방송 선택
Select normal or emergency broadcast
- 전체 선택 및 취소
All zone selector
- 그룹 선택 및 취소
Group selector
- 개별 방송 선택 및 취소
Individual zone selector
- 운영 모드
Operation mode
- 예약 방송
Timer function
- 장비 설정
Unit setting
- 환경 설정
Preferences

DIGITAL EMERGENCY MAIN CONTROLLER

EDC-1000



SPECIFICATION	
PRIORITY ORDER	EM > EXT1 > TIMER > RM1 > RM2 > PC > BGM
CHANNEL	16 Channels
COMMUNICATION METHOD	LINK IN/OUT : CAN Remote Amp, PC control : RS-422 (Max:1km) Source : RS-485 (Max:1km)
FIRE SENSOR INPUT	16CH contact or data
OPERATING TEMPERATURE	-10℃ ~ 40℃
POWER SOURCE	DC 24V, 1A
WEIGHT	5.2kg
DIMENSION	482(W) × 132(H) × 280(D) mm

- 비상판넬, 비상스위치, 매트릭스, 릴레이그룹, 스피커 셀렉터, 터미널 보드가 통합된 장비
- 비상 신호 장비와 리모트 마이크 ERM-1000과 연결하여 우선 순위 방송 제어
- EDS-1000 15대를 추가 설치하여 총 256채널 화재 접점 가능
- 수동으로 비상 또는 일반 방송 선택 및 송출 가능
- 우선 순위 및 각 채널의 방송 상태를 LED로 표시
- 3선식 방송을 할 수 있도록 일반 방송과 비상 방송에 대한 채널 구성
- PC 장애 발생 시에도 저장된 정보를 통해 정상적 운영 가능
- RS-422 통신을 채택하여 PC를 통해 장거리 방송 가능
- 통합 시스템이므로 연결이 간단하여 설치 시간과 공간 절약
- Combination of emergency panel, emergency switch, matrix, relay group, speaker selector, and terminal board
- Priority broadcast is available connecting with fire system and remote amp (ERM-1000)
- Able to expand maximum 256 channels by adding EDS-1000
- Able to select normal broadcast or emergency broadcast by manual
- LED indicators showing priority status and each channel's status
- Stored information enables normal operation even if PC is in fail
- RS-422 communication method for remote broadcast by PC
- Easy installation and saving time and space due to combined system

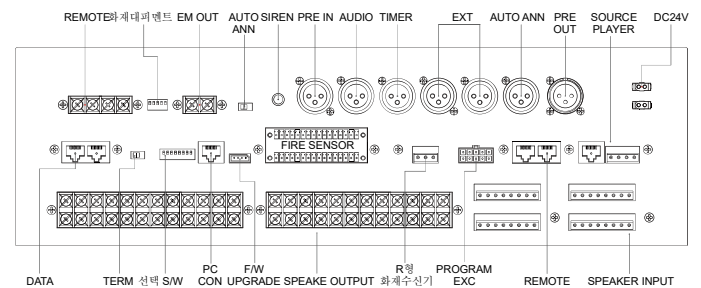

DIGITAL EMERGENCY SUB CONTROLLER

EDS-1000



SPECIFICATION	
PRIORITY ORDER	EM > EXT1 > TIMER > RM1 > RM2 > PC > BGM
CHANNEL	16 Channels
COMMUNICATION METHOD	LINK IN/OUT : CAN
FIRE SENSOR INPUT	16CH contact
OPERATING TEMPERATURE	-10℃ ~ 40℃
POWER SOURCE	DC 24V, 1A
WEIGHT	5.2kg
DIMENSION	482(W) × 88(H) × 280(D) mm

- 비상스위치, 릴레이그룹, 스피커 셀렉터, 터미널 보드가 통합된 장비
- 비상 신호 장비와 리모트 마이크 ERM-1000과 연결하여 우선 순위 방송 제어
- EDS-1000 15대를 추가 설치하여 총 256채널 화재 접점 가능
- 수동으로 비상 또는 일반 방송 선택 및 송출 가능
- 우선 순위 및 각 채널의 방송 상태를 LED로 표시
- 3선식 방송을 할 수 있도록 일반 방송과 비상 방송에 대한 채널 구성
- PC 장애 발생 시에도 저장된 정보를 통해 정상적 운영 가능
- RS-422 통신을 채택하여 PC를 통해 장거리 방송 가능
- 통합 시스템이므로 연결이 간단하여 설치 시간과 공간 절약
- Combination of emergency switch, relay group, speaker selector, and terminal board
- Priority broadcast is available connecting with fire system and remote amp (ERM-1000)
- Able to expand maximum 256 channels by adding EDS-1000
- Able to select normal broadcast or emergency broadcast by manual
- LED indicators showing priority status and each channel's status
- 3-line wiring is available for normal and emergency broadcast
- Stored information enables normal operation even if PC is in fail
- RS-422 communication method for remote broadcast by PC
- Easy installation and saving time and space due to combined system

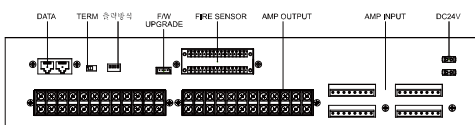

DIGITAL REMOTE INTERFACE

ERI-1000



SPECIFICATION	
COMMUNICATION METHOD	RS-422
CONTROL RANGE	ERM-1000, EDC-1000
DISPLAY	LED DISPLAY
POWER SOURCE	DC 24V / 100mA
WEIGHT	3.1kg
DIMENSION	482(W) × 44(H) × 280(D) mm

- ERM-1000에서 방송 시, 해당 채널의 LED 점등 표시
- ERM-1000에서 선택한 채널을 동시에 열어 방송할 수 있는 전체 동작 모드와 ERM-1000에 설정된 우선 순위에 의해 방송하는 우선 순위 동작 모드로 구성
- RS-422 통신방식 / 속도 : 115.2kbps
- Light on the selected channels of ERM-1000
- Two modes of broadcast :
 - 1) Open the channel of selected channels of ERM-1000
 - 2) Open the channel in order of priority of ERM-1000
- Communication method is RS-422 and speed is 115.2kbps

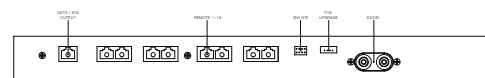

EMERGENCY REMOTE AMPLIFIER

ERM-1000



SPECIFICATION	
COMMUNICATION METHOD	RS-422
CONTROL RANGE	EDC-1000 or ERI-1000
EXTERNAL INPUT	AUDIO INPUT TERMINAL
DISPLAY	LED DISPLAY
POWER SOURCE	DC 24V / 110mA
WEIGHT	1.5kg
DIMENSION	266(W) × 50(H) × 203(D) mm

- 방송하고자하는 채널과 그룹을 선택하여 방송 가능
- 리모트 앰프 별로 우선 순위 설정 가능
- 외부기기 음원 방송 가능
- RS-422 통신방식 / 속도 : 115.2kbps
- Individual and group broadcast is available remotely
- Able to set a priority order for each ERM-1000 when using more than one piece
- Able to broadcast external device's source
- Communication method is RS-422 and speed is 115.2kbps

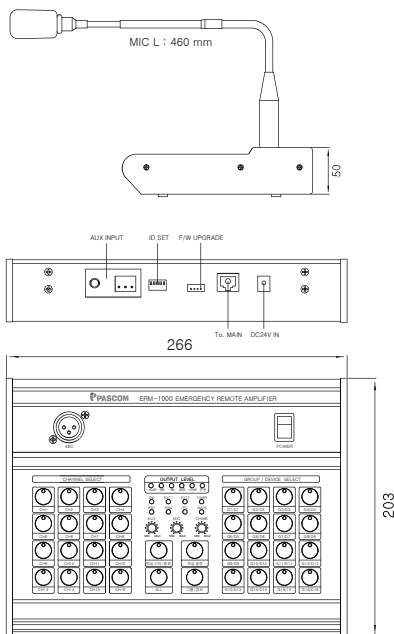

DIGITAL EMERGENCY MAIN SPEAKER CONTROLLER

ESS-2016M



SPECIFICATION	
PRIORITY ORDER	EM > TIMER > RM1 > RM2 > BGM
CHANNEL	16 Channels
COMMUNICATION METHOD	LINK IN/OUT : CAN Remote Amp : RS-422 (Max : 1km)
FIRE SENSOR INPUT	16CH contact or data
OPERATING TEMPERATURE	-10℃ ~ 40℃
POWER SOURCE	DC 24V, 1A
WEIGHT	5.2kg
DIMENSION	482(W) × 88(H) × 280(D) mm

- 비상스위치, 매트릭스, 릴레이그룹, 스피커 셀렉터, 터미널 보드가 통합된 장비
- 비상 신호 장비와 리모트 마이크 ERM-1000과 연결하여 우선 순위 방송 제어
- ESS-2016S 15대를 추가 설치하여 총 256채널 화재 접점 가능
- 수동으로 비상 또는 일반 방송 선택 및 송출 가능
- 우선 순위 및 각 채널의 방송 상태를 LED로 표시
- 3선식 방송을 할 수 있도록 일반 방송과 비상 방송에 대한 채널 구성
- PC 장애 발생 시에도 저장된 정보를 통해 정상적 운영 가능
- 통합 시스템이므로 연결이 간단하여 설치 시간과 공간 절약
- Combination of emergency switch, matrix, relay group, speaker selector, and terminal board
- Priority broadcast is available connecting with fire system and remote amp (ERM-1000)
- Able to expand maximum 256 channels by adding EDS-1000
- Able to select normal broadcast or emergency broadcast by manual
- LED indicators showing priority status and each channel's status
- 3-line wiring is available for normal and emergency broadcast
- Stored information enables normal operation even if PC is in fail
- Easy installation and saving time and space due to combined system

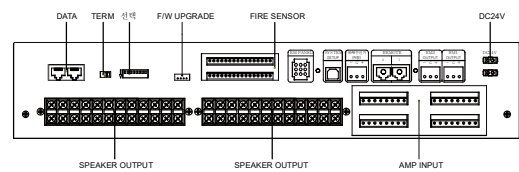

DIGITAL EMERGENCY SUB SPEAKER CONTROLLER

ESS-2016S



SPECIFICATION	
PRIORITY ORDER	EM > TIMER > RM1 > RM2 > BGM
CHANNEL	16 Channels
COMMUNICATION METHOD	LINK IN/OUT : CAN Remote Amp : RS-422 (Max : 1km)
FIRE SENSOR INPUT	16CH contact or data
OPERATING TEMPERATURE	-10℃ ~ 40℃
POWER SOURCE	DC 24V, 1A
WEIGHT	5.2kg
DIMENSION	482(W) × 88(H) × 280(D) mm

- 비상스위치, 매트릭스, 릴레이그룹, 스피커 셀렉터, 터미널 보드가 통합된 장비
 - 비상 신호 장비와 리모트 마이크 ERM-1000과 연결하여 우선 순위 방송 제어
 - ESS-2016S 15대를 추가 설치하여 총 256채널 화재 접점 가능
 - 수동으로 비상 또는 일반 방송 선택 및 송출 가능
 - 우선 순위 및 각 채널의 방송 상태를 LED로 표시
 - 3선식 방송을 할 수 있도록 일반 방송과 비상 방송에 대한 채널 구성
 - PC 장애 발생 시에도 저장된 정보를 통해 정상적 운영 가능
 - 통합 시스템이므로 연결이 간단하여 설치 시간과 공간 절약
-
- Combination of emergency switch, matrix, relay group, speaker selector, and terminal board
 - Priority broadcast is available connecting with fire system and remote amp (ERM-1000)
 - Able to expand maximum 256 channels by adding EDS-1000
 - Able to select normal broadcast or emergency broadcast by manual
 - LED indicators showing priority status and each channel's status
 - 3-line wiring is available for normal and emergency broadcast
 - Stored information enables normal operation even if PC is in fail
 - Easy installation and saving time and space due to combined system

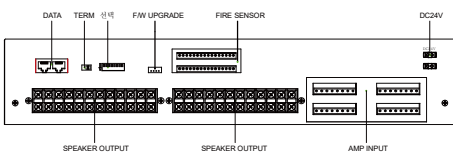

DIVERSIFIED PA SYSTEM

DMS-8SW	DMS-8 Series PC operating software	24
DMS-8SV	Digital Signal Converter	24
DMS-8MC	Digital Main Controller	25
DMS-8ESC	Digital Emergency Speaker Controller	26
DMS-8PS	Digital Power Supply	26
DMS-8RIM	Remote Interface & Matrix	27



PC Software

DMS-8SW

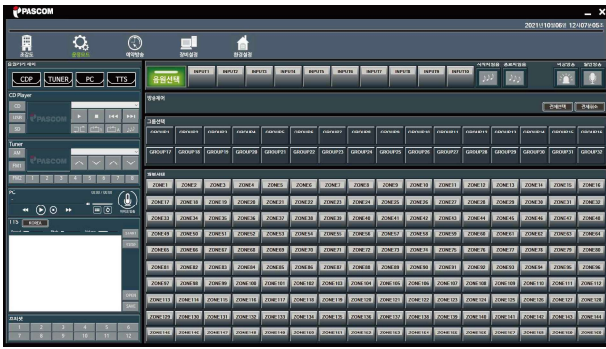

- 소스 기기 조작
Source Controller
- PC 마이크 & BGM 조작
PC MIC & BGM Controller
- 문자방송 (TTS) 조작
Text to Sound (TTS) Function
- 프리셋 설정
Preset Setting
- 입력 음원 선택
Selecting Source
- 시작 차임 & 종료 차임
Start Chime & End Chime
- 비상 방송 or 일반 방송 선택
Select normal or emergency broadcast
- 전체 선택 및 취소
All zone selector
- 그룹 선택 및 취소
Group selector
- 개별 방송 선택 및 취소
Individual zone selector
- 운영 모드
Operation mode
- 예약 방송
Timer function
- 장비 설정
Unit setting
- 환경 설정
Preferences

DIGITAL SIGNAL CONVERTER

DMS-8SV



SPECIFICATION	
COMMUNICATION METHOD	RS-422
CONTROL RANGE	DMS-8MC
DISPLAY	LED
POWER SOURCE	USB Power (DC 5V)
WEIGHT	1kg
DIMENSION	160(W) × 44(H) × 140(D) mm

- PC USB 단자를 통해 시스템 제어가 가능하도록 USB to UART 컨버터 내장
- BALANCE 형식으로 오디오 신호를 전달하여 원거리에서도 적은 음원 전달 손실
- 다이내믹 마이크를 연결하여 방송이 가능하며 우선순위 (MIC>BGM) 선택 가능
- USB to UART converter is embedded for controlling system by PC USB terminal
- Minimize the audio loss by transferring audio signal as BALANCE type
- Broadcast by dynamic microphone is available
- Able to choose priority order (MIC>BGM)

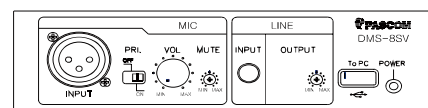
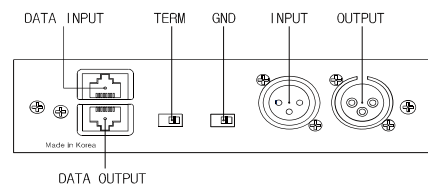

DIGITAL MAIN CONTROLLER

DMS-8MC



SPECIFICATION	
CPU	ARM Cortex M4, 180MHz
MEMORY	PROGRAM 1M
LCD	7" (800×480) with touch screen
AUDIO INPUT CHANNEL	14CH
UART PORT	3 PORT
CAN PORT	1 PORT
OUTPUT LEVEL	0dBV (Balanced)
INPUT SENSITIVITY	EM, TIMER, RM : -10dBV/20kΩ (Balanced) BGM 1~8 LINE : -10dBV/3kΩ (Balanced) BGM 1~8 MIC : -50dBV/3kΩ (Balanced) BGM 9~10 LINE : -10dBV/3kΩ (Unbalanced)
FREQUENCY RESPONSE	±3dB : 20Hz ~ 20kHz
T.H.D	LINE : ≤0.5% MIC : ≤0.5%
S/N	LINE : ≥70dB
PHANTOM MIC VOLTAGE	BGM 1,2 : DC 15V
PRIORITY ORDER	EM > TIMER > RM1 > RM2 > BGM
OPERATING TEMPERATURE	-10℃ ~ +40℃
POWER SOURCE	DC 24V / 1A
WEIGHT	4.3kg
DIMENSION	482(W) × 132(H) × 280(D) mm

- 메인 컨트롤 장비를, 전면의 터치 스크린과 PC 운영 프로그램을 통해 설정된 시스템 정보를 저장하여 운영
- 14개의 다양한 오디오 입력(EM, TIMER, RM×2, BGM×10)에 대한 8개의 출력을 제어하는 오디오 매트릭스 기능
- 화재 시 비상방송이 최우선으로 출력되며 자동 방송과 수동 방송 선택 가능
- 데이터 방식은 장비 후면의 R형 DATA 단자와 연동하고, 점점 방식은 DMS-8ESC와 연동
- 일반 방송 또는 BGM 방송중이라도 비상, 타이머, 리모트 마이크 방송 등의 우선 순위에 따라 방송이 자동 전환
- 2채널의 COMBO 잭, 6채널의 XLR 잭, 2채널의 RCA 잭 등, 입력 단자를 통해 다양한 BGM 음원 입력 가능
- 채널 1번과 2번을 통해 콘덴서 마이크 (15V PHANTOM POWER)를 사용할 수 있으며 후면 스위치를 통해 MIC/LINE 입력 선택 가능
- 전면의 프리셋 메모리 버튼으로 일반 방송을 편리하게 설정 및 방송 가능
- 다양한 업체의 화재수신기와 연동 가능한 뛰어난 호환성
- Setting applied by touch screen and PC S/W is saved in the unit for operation
- Matrix PA system of 14 inputs (EM, TIMER, RM×2, BGM×10) and 8 outputs
- DATA terminal at rear for connecting with data type fire system, and DMS-8ESC enables connecting with contact type fire system
- Automatically convert to emergency broadcast, timer, or remote according to it's priority order even if normal broadcast or BGM is on
- Various BGM source can be input through 2CH of COMBO jack, 6CH of XLR jack, and 2CH of RCA etc.
- Able to use condensor microphone (15V PHANTOM POWER) through CH1 and CH2, and able to select MIC/LINE by switch in rear
- Easy to set or broadcast by PRESET memory button in front

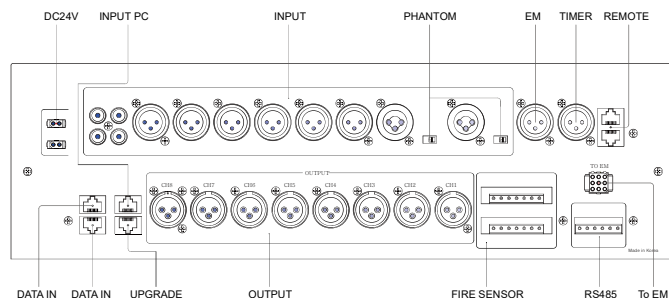

DIGITAL EMERGENCY SPEAKER CONTROLLER

DMS-8ESC



SPECIFICATION	
CHANNEL	16 Channels
COMMUNICATION METHOD	LINK IN/OUT : CAN(1km) Source & Voice file : RS-232(12m)
FIRE SENSOR INPUT	16CH contact
OPERATING TEMPERATURE	-10°C ~ +40°C
POWER SOURCE	DC 24V, 600mV
WEIGHT	4.3kg
DIMENSION	482(W) × 88(H) × 280(D) mm

- 릴레이그룹, 스피커셀렉터, 비상인터페이스, 터미널보드 기능이 통합된 시스템
- DMS-8MC 와 연동하여 16채널의 화재 접점을 통해 해당 채널로 화재방송 자동 송출
- 원하는 채널의 방송을 전면 스위치로 조작하여 수동 제어 가능
- 2선식, 3선식 방송을 할 수 있도록 일반 방송과 비상 방송에 대한 채널 구성
- DMS-8ESC 9대를 추가 설치하여 총 160채널까지 확장 가능
- CAN 통신을 사용하여 장거리 전송 가능
- 통합 시스템이므로 연결이 간단하여 설치 시간과 공간 절약
- Combination of speaker selector, emergency interface, terminal board
- By connecting with DMS-8MC, contact signal enables automatic emergency broadcast
- Able to select channels to broadcast by manual
- 2 and 3-line wiring are available for both normal and emergency broadcast
- Able to expand maximum 160 channels by adding DMS-8ESC
- CAN communication method for fast transferration transmission
- Easy installation and saving time and space due to combined system

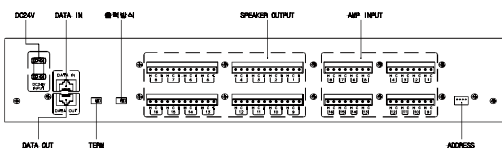

DIGITAL POWER SUPPLY

DMS-8PS



SPECIFICATION	
COMMUNICATION METHOD	FSK PLC, 2400bps
CONTROL RANGE	DMS-8LR
SUPPLY POWER	DC 24V / 8A
DISPLAY	LED
POWER SOURCE	AC 220V / 50Hz, 60Hz
WEIGHT	1.5kg
DIMENSION	482(W) × 88(H) × 280(D) mm

- 공급 전압과 소비 전류를 전면에 숫자로 표시하여 총 소비전력 또는 단선 등 파악 용이
- SMPS 스위칭 방식 설계로 고성능의 전원 공급 가능
- 정전 시 연결되어 있는 배터리로 전원 공급 전환
- State supplying power and current consumption in front display to know power consumption or short circuit easily
- SMPS switching method enables high quality power supply
- Supply power by battery in case of blackout

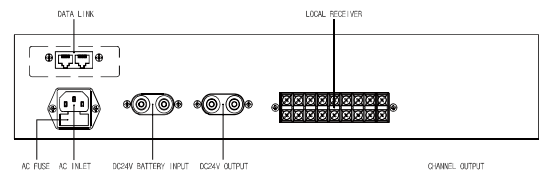

REMOTE INTERFACE & MATRIX

DMS-8RIM



SPECIFICATION	
DISPLAY	CANNEL LED
CHANNEL	8IN / 8OUT Channels
COMMUNICATION METHOD	RS-422 (Max : 1km)
COMMUNICATION SPEED	115,200 bps, N , 8, 1
PROCESSOR	32bit Embedded Microprocessor
POWER SOURCE	DC 24V, 500mA
WEIGHT	3.8kg
DIMENSION	482(W) × 88(H) × 280(D) mm

- ERM-1000(리모트앰프)을 8대 단위로 최대 16대 확장 가능
- 전체 동작 운영 모드 및 우선순위 자동 전환 운용 모드로 사용 가능
- 사용자 위주 설계 반영으로 조작하기 쉬우며, 동작중인 채널 LED 점등으로 표시
- 리모트앰프(ERM-1000)의 8X8 매트릭스 오디오 출력 기능
- 입,출력 회로에 ACTIVE BALANCED 회로 채택, 외부 잡음의 유입 차단 기능
- 실시간 처리 방식 구현으로 즉각 제어 가능

- ERM-1000 (remote amplifier) can be expanded to a maximum of 16 units in 8-unit units.
- Available in full motion operation mode and priority auto-switching operation mode
- Easy to operate with user-centered design, and operating channel LED lights indicate the current channel.
- 8X8 matrix audio output function of the remote amplifier (ERM-1000)
- Adoption of ACTIVE BALANCED circuit in input/output circuits, function to block external noise
- Real-time processing allows for immediate control

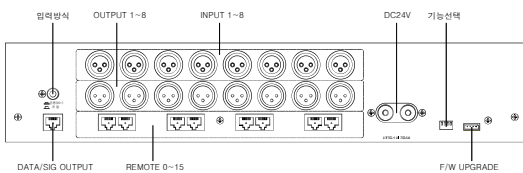

DIGITAL RX-TX PA SYSTEM

SW-9600	RX-TX System PC operating software(Client)	30
SW-9601	RX-TX System PC operating software (Server)	30
DSV-9600	Digital Signal Converter	31
DCV-9600	Digital Data Converter	31
DMC-9600SE	Digital Main Controller	32
DPS-9600	Digital Power Supply(V1)	32
DSC-9600	Digital Speaker Controller	33
DRG-9600	Digital Relay Group	33
DEI-9600	Digital Emergency Interface	34
PRX-3100	Local Receiver(V1) & Line Checker	34
DRA-9600	Digital Remote Amplifier	35
DRI-9600	Digital Remote Interface	35

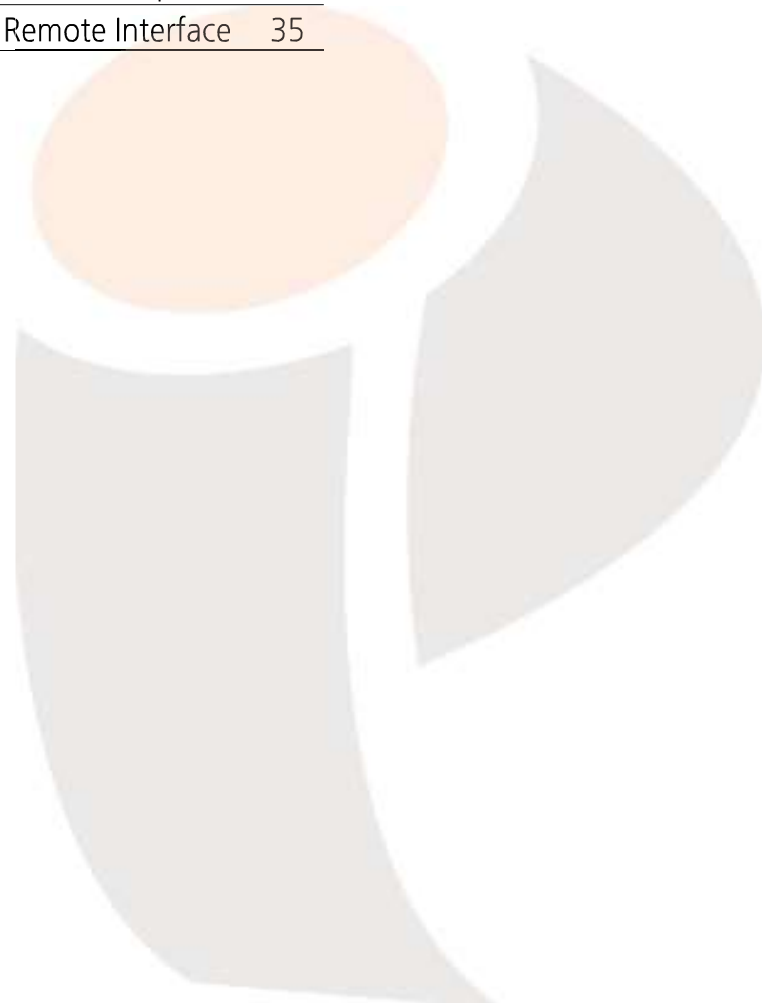

PC Software (Client)

SW-9600

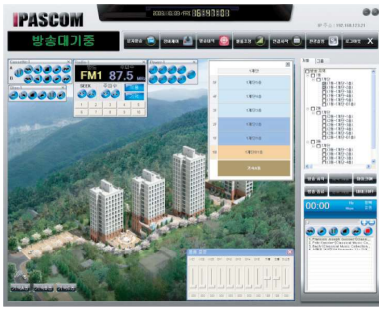

- 조작이 쉬운 사용자 중심적 원터치 방식 인터페이스
- 조감도 또는 배치도 변경 가능
- 화재 발생 시 해당 위치를 조감도 또는 배치도 위에 표시하며, 해당 건물의 발화 층을 알기 쉽게 표시
- 방송하고자 하는 개별 지역 또는 그룹을 지정하여 방송 가능
- 개별 지역 또는 그룹 명칭을 사용자 임의로 변경 가능
- 동-계단-층 단위를 사용하는 아파트 운용 방식과 명칭 단위의 건물이나 학교 등에 사용 가능한 운용방식 간에 변경 가능
- 사용자가 원하는 시간에 방송을 예약하여 관리 가능
- 방송 내역, 화재 발생 내역, 예약 방송 등 내용을 데이터 베이스에 기록, 보관하며 원하는 기간의 방송 내역 인쇄 가능
- User-centered one touch interface for easy use
- Able to change bird-eye view or layout
- Mark the location on bird's eye view or layout drawing where the fire is
- Able to select individual zone or group to broadcast
- Able to change the name of each zone at your convenience
- Able to select the operation mode between apartment mode and building mode (for other than apartment)
- Timer function to broadcast at needed time
- S/W saves a history of broadcasts, fires, and timers into a data base, able to print broadcast history of needed period

PC Software (Server)

SW-9601



- 조작이 쉬운 사용자 중심적 원터치 방식 인터페이스
- 등록된 SW-9600 IP 주소를 통해 방송상태, 접속상태, 장비상태 모니터링 가능
- 동-계단-층 단위를 사용하는 아파트 운용 방식과 명칭 단위의 건물이나 학교 등에 사용 가능한 운용방식 간에 변경 가능
- 사용자가 원하는 시간에 방송을 예약하여 관리 가능
- 방송 내역, 화재 발생 내역, 예약 방송 등 내용을 데이터 베이스에 기록, 보관하며 원하는 기간의 방송 내역 인쇄 가능
- User-centered one touch interface for easy use
- Monitoring broadcast status, connection, unit status by registered SW-9600 IP address
- Able to select the operation mode between apartment mode and building mode (for other than apartment)
- Timer function to broadcast at needed time
- S/W saves a history of broadcasts, fires, and timers into a data base, able to print broadcast history of needed period

DIGITAL SIGNAL CONVERTER

DSV-9600



SPECIFICATION	
COMMUNICATION METHOD	2400bps, PLC
CONTROL RANGE	DCV-9600
DISPLAY	USB (DC 5V)
POWER SOURCE	DC 24V / 122mA
WEIGHT	200g
DIMENSION	105(W) × 30(H) × 110(D) mm

- 현재 통신중인 장비의 통신 상태 LED 표시
- 오디오 신호를 BALANCE 형식으로 변환하여 전달하므로 원거리에서도 적은 음원 손실
- PLC : DCV-9600
통신속도 : 2400bps, N, 8, 1
- Indicate the currently communicating unit's status by LED
- Convert the audio signal to BALANCE type that enables minimal audio loss
- PLC : DCV-9600
Communication speed : 2400bps, N, 8, 1

DIGITAL DATA CONVERTER

DCV-9600



SPECIFICATION	
COMMUNICATION METHOD	2400bps, RS-485, PLC
CONTROL RANGE	DPA series
DISPLAY	LED
POWER SOURCE	DC 24V / 300mA
WEIGHT	1.2kg
DIMENSION	482(W) × 44(H) × 280(D) mm

- 현재 통신중인 장비의 통신 상태 LED 표시
- 장비 간 통신 프로토콜을 분석하여 PLC와 RS-485를 자동 구분하여 통신
- RS-485 통신 방식 : DRG-9600
PLC : PRX-3100, DRA-9600, DMC-9600SE
통신 속도 : 2400bps, N, 8, 1
- Indicate the currently communicating unit's status by LED
- Analyze a communication protocol of units and automatically sort PLC and RS-485
- RS-485 : DRG-9600
PLC : PRX-3100, DRA-9600, DMC-9600SE
Communication speed : 2400bps, N, 8, 1

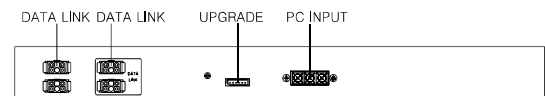
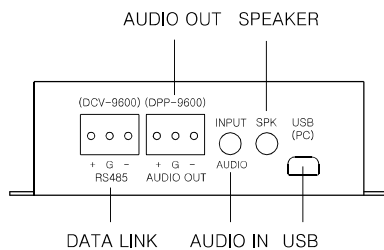

DIGITAL MAIN CONTROLLER

DMC-9600SE



SPECIFICATION	
COMMUNICATION METHOD	2400bps, RS-485
CONTROL RANGE	DRG-9600, DRA-9600, EMP-1000
EXTERNAL CONTROL	NO, NC, DC 24V output & 2CH input
DISPLAY	LED, 128x64 Graphics LCD
POWER SOURCE	DC 24V / 80mA
WEIGHT	1kg
DIMENSION	482(W) × 88(H) × 280(D) mm

- 일반 방송 및 화재 방송 가능
- 다양한 화재 수신기 연동
- 리모트 앰프 DRA-9600으로 원격지에서 DMC-9600SE의 기능 통제 가능
- 데이터 링크로 S/W와 연동하여 원격 제어 및 감시 가능
- 점검 및 시험운용 기능이 있어 자체 시험 가능
- 조작이 쉬운 사용자 중심적 운영 방식
- RS-485 통신방식 : R형 화재수신기 (9600bps, N, 8, 1), DRG-9600(Relay Group) 등
- 전력선 통신방식 : PRX-3100
- 통신속도 : 1200bps ~ 9600bps 선택가능
- Normal broadcast and emergency broadcast available
- Possible to link a various kind of fire system
- Able to control DMC-9600SE by DRA-9600(remote amplifeir)
- Data link enables remote controlling the S/W
- Self-testing available
- User-centered design for easy use
- RS-485 communication : data type fire system (9600bps, N, 8, 1) DRG-9600(Relay Group) etc.
- Power line communication : PRX-3100
- Communication speed : 1200bps ~ 9600bps (Selectable)

DIGITAL POWER SUPPLY

DPS-9600



SPECIFICATION	
COMMUNICATION METHOD	FSK PLC, 2400bps
CONTROL RANGE	PRX-3100
DISPLAY	LED
SUPPLY POWER	DC 24V / 8A
POWER SOURCE	AC 220V / 50Hz, 60Hz
WEIGHT	1.5kg
DIMENSION	482(W) × 88(H) × 280(D) mm

- 공급 전압과 소비 전류를 전면에 숫자로 표시하여 총 소비전력 또는 단선 등 파악 용이
- SMPS 스위칭 방식 설계로 고성능의 전원 공급 가능
- 정전 시 연결되어 있는 배터리로 전원 공급 전환
- State supplying power and current consumption in front display to know power consumption or short circuit easily
- SMPS switching method enables high quality power supply
- Supply power by battery in case of blackout

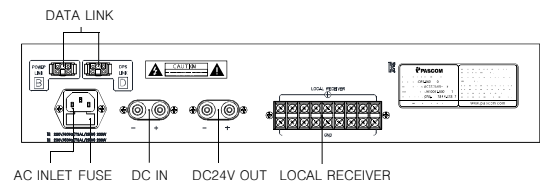
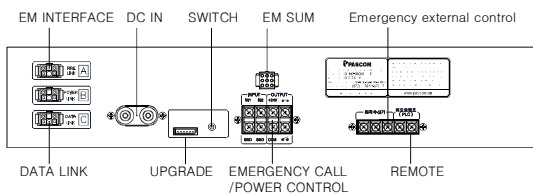

DIGITAL SPEAKER CONTROLLER

DSC-9600



SPECIFICATION	
COMMUNICATION METHOD	2400bps, RS-485
CONTROL RANGE	DRG-9600 normal broadcast 16CH
DISPLAY	LED for every channel
POWER SOURCE	DC 24V / 137mA
WEIGHT	1.8kg
DIMENSION	482(W) × 44(H) × 280(D) mm

- 일반방송 기능
- 각 채널별 LED가 있어 일반 방송 상태 확인 가능
- 일반 방송과 비상방송(MIC) 개별 및 전체 방송 가능
- RS-485 통신방식 : DRG-9600
통신속도 : 2400bps
- Able to turn ON/OFF the normal broadcast
- LED display enables you to know a status of broadcast
- Normal and emergency(MIC) broadcast for individual or all channels
- RS-485 communication : DRG-9600
Communication speed : 2400bps

DIGITAL RELAY GROUP

DRG-9600



SPECIFICATION	
COMMUNICATION METHOD	2400bps, RS-485
CONTROL RANGE	TB-9616 normal & emergency 16CH
DISPLAY	LED DISPLAY for every channel
POWER SOURCE	DC 24V / 618mA
WEIGHT	2kg
DIMENSION	482(W) × 44(H) × 280(D) mm

- DMC-9600SE에 의한 일반 방송 ON/OFF 가능
- DMC-9600SE에 의한 비상 방송 ON/OFF 가능
- 각 채널별 LED가 있어 일반 방송 시 점등, 비상 방송 시 점멸로 구분 가능
- 일반 방송과 비상 방송 개별 및 전체 방송 가능
- RS-485 통신방식 : DMC-9600SE, DSC-9600
통신속도 : 2400bps
- Able to turn ON/OFF the normal broadcast by DMC-9600SE
- Able to turn ON/OFF the emergency broadcast by DMC-9600SE
- LED display enables you to know a status of broadcast
- Light ON : Normal broadcast
- Light blink : Emergency broadcast
- Normal and emergency broadcast for individual or all channels
- RS-485 communication : DMC-9600SE, DSC-9600
Communication speed : 2400bps

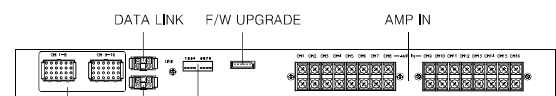
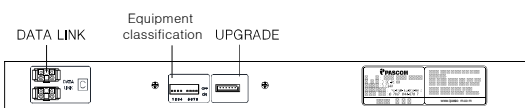

SPEAKER OUT DATA LINK Equipment classification (TB-9616)

DIGITAL EMERGENCY INTERFACE

DEI-9600



SPECIFICATION	
COMMUNICATION METHOD	9600bps, RS-485
CONTROL RANGE	DMC-9600SE
EXTERNAL INPUT	Standard DC 24V fire system
DISPLAY	LED
POWER SOURCE	DC 24V / 370mA
WEIGHT	1.5kg
DIMENSION	482(W) × 44(H) × 280(D) mm

- 화재 발생 시 화재 발생 동, 층을 식별할 수 있도록 LED 표시
- DMC-9600SE 장비와 연동하여 화재 발생 시 발생 현황을 LED에 표시 및 빛과 소리로 알림
- RS-485 통신방식 : DMC-9600SE
통신속도 : 9600bps, N, 8, 1
- LED indicate a status of fire
- Indicate a status of fire by LED or sound by connecting with mode
- RS-485 communication : DMC-9600SE
Communication Speed : 9600bps, N, 8, 1

LOCAL RECEIVER & LINE CHECKER

PRX-3100

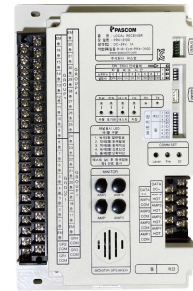

SPECIFICATION	
COMMUNICATION METHOD	PLC, 2400bps
CONTROL RANGE	DMC-9600SE, DRA-9600
EXTERNAL INPUT	LED DISPLAY for every channel
DISPLAY	LED
POWER SOURCE	DC 24V / 600mA
WEIGHT	1.5kg
DIMENSION	270(W) × 52(H) × 166(D) mm

- 전원 라인으로 통신 데이터를 함께 공급 받도록 설계하여 간편한 설치
- 각 채널의 스피커 선로 이상 유무 확인 기능
- 라인 체크 후 이상 구역은 자동으로 차단하여 앰프 보호
- 모니터 스피커를 내장하여 파워 앰프의 오디오 신호 확인 가능
- LED 상태 표시 기능
- 수동으로 전체 방송 가능
- 초기화 스위치를 눌러 라인 상태 초기화 가능
- Less wiring because the data comes in through power line
- Able to check each channel's speaker condition
- After checking lines, abnormal channel is automatically blocked cut off to protect the amp
- Embedded monitor speaker enables you to check the audio signal of power amp
- Indicate the condition by LED
- Able to broadcast to all channels by manual
- Able to reset the condition of lines by reset switch

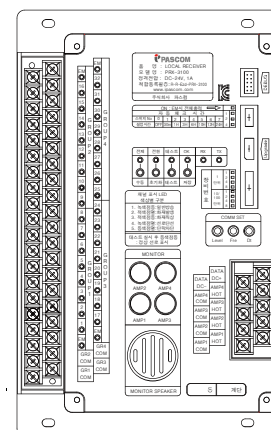
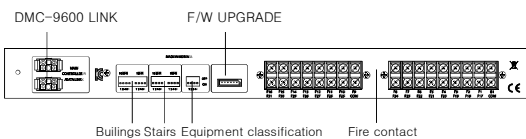

DIGITAL REMOTE AMPLIFIER

DRA-9600



SPECIFICATION	
COMMUNICATION METHOD	2400bps, RS-485, PLC
CONTROL RANGE	DMC-9600SE
EXTERNAL INPUT	UNBALANCE AUDIO INPUT 1CH
	LED, 128×64 Graphics LCD
POWER SOURCE	DC 24V / 122mA
	1kg
DIMENSION	235(W) × 200(H) × 65(D) mm

- 일반방송 및 화재방송 기능
- 마이크 방송 도중 일정시간(약10초) 동안 마이크 입력이 없을 경우 자동 종료
- 리모트 앰프별로 우선 순위를 지정하여 순위 값으로 우선 방송 가능
- 외부기기 음원을 입력 받아 방송 가능
- RS-485, PLC 통신방식
통신속도 : 1200bps ~ 9600bps (selectable)
- Normal or emergency broadcast available
- If nothing is input while mic broadcast (about 10secs), the broadcast automatically ends
- Able to broadcast in order of priority
- Able to broadcast sources from external devices
- Communication method : RS-485, PLC
Communication speed : 1200bps ~ 9600bps (selectable)

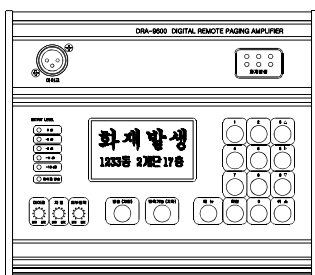
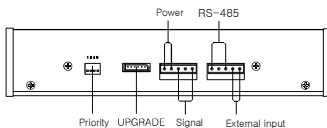

DIGITAL REMOTE INTERFACE

DRI-9600



SPECIFICATION	
COMMUNICATION METHOD	2400bps, RS-485
CONTROL RANGE	PRX-3100, DMC-9600SE
EXTERNAL INPUT	AUDIO INPUT TERMINAL
DISPLAY	LED
POWER SOURCE	DC 24V / 200mA
WEIGHT	1kg
DIMENSION	482(W) × 44(H) × 280(D) mm

- DRA-9600에서 방송 시 해당 채널의 LED를 점등하여 표시
- 우선 순위 방식으로 운영되더라도 화재 시에는 자동으로 전체 방송 전환
- DRA-9600에서 선택한 채널을 동시에 열어 방송할 수 있는 전체 동작 모드와 DRA-9600에 설정된 우선 순위에 의해 방송하는 우선 순위 동작 모드로 구성
- PLC : DRA-9600, DMC-9600SE
- Light on the selected channels of DRA-9600
- Two modes of broadcast :
 - 1) Open the channel of selected channels of DRA-9600
 - 2) Open the channel in order of priority of DRA-9600
- PLC : DRA-9600, DMC-9600SE
- Communication speed : 2400bps, N, 8, 1

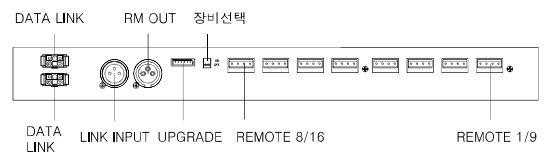

ANALOG PA SYSTEM

PX-9600	Matrix	38
PS-9616I	Indirect Speaker Selector	38
RG-9600	Relay Group	39
ES-9600	Emergency Switcher	39
ESS-9642	Emergency Speaker Switcher	40
PS-9616	Direct Speaker Selector	40
RM-9616	Remote Paging Microphone	41
RE-9600	Remote Exchanger	41



MATRIX

PX-9600



INDIRECT SPEAKER SELECTOR

PS-9616I



SPECIFICATION	
RELAY GROUP CONTROL LINE	16 LINES
RM1, RM2, SPEAKER SELECT LINE	16 LINES
EMERGENCY CONTROL LINE	5 LINES
POWER SOURCE	DC 24V, 0.8W
WEIGHT	4.4kg
DIMENSION	482(W) × 44(H) × 280(D) mm

SPECIFICATION	
SPEAKER CONTROL LINE	16 LINES
OUTPUT CONTROL	ALL, GROUP, INDIVIDUAL
INDICATING LED	INDIVIDUAL, GROUP1, GROUP2, ALL
POWER SOURCE	DC 24V
WEIGHT	3.8kg
DIMENSION	482(W) × 44(H) × 280(D) mm

- 우선 순위에 의한 방송 가능
- 2선식 및 3선식 방송 가능
- 정전 시에도 시스템을 동작시키기 위한 배터리 전원 입력 기능 탑재
- 일반방송, 원격제어, 타이머의 입력 제어 기능으로 방송하고자 하는 신호 제어 가능
- Broadcast in priority available
- 2-wire and 3-wire broadcast available
- Battery power input function for operating in case of blackout
- Control the input of normal broadcast, remote control, and timer

- 비상 방송 모델의 일반 방송 스피커를 간접으로 제어
- 개별, 그룹1(CH1~8), 그룹2(CH9~16), 전체 선택 스위치가 있어 편리한 동작
- 각 스위치마다 LED가 있어 선택된 회선 확인 용이
- Control normal broadcast's speakers indirectly
- Switches for individual, GROUP1(CH1~8), GROUP2(CH9~16), and ALL
- LED indicates which line is selected

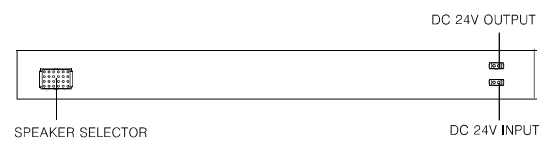
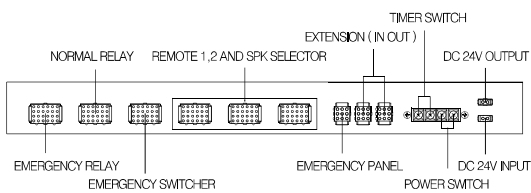

RELAY GROUP

RG-9600



SPECIFICATION	
INPUT SIGNAL LINE	16 LINES
OUTPUT SIGNAL LINE	16 LINES
CONTROL LINE	16 LINES
POWER SOURCE	DC 24V
WEIGHT	5.1kg
DIMENSION	482(W) × 44(H) × 280(D) mm

- PX-9600과 연결하여 릴레이를 동작시켜 스피커 선로 제어
- 2선식, 3선식 방송 가능
- 일반 및 비상 방송 시 동작하고 있는 회선을 LED로 표시하여 쉽게 확인 가능
- Control the lines of speakers by connecting with PX-9600
- 2 and 3-line wiring are available for both normal and emergency broadcast
- LED for indicating the line which is now broadcasting

EMERGENCY SWITCHER

ES-9600



SPECIFICATION	
FIRE DETECTION LINE	16 LINES
FIRE & EMERGENCY LED	ALL, GROUP, INDIVIDUAL
POWER SOURCE	DC 24V
WEIGHT	4.2kg
DIMENSION	482(W) × 44(H) × 280(D) mm

- 16개의 자동 화재 감지에 의하여 발화층과 직상층의 회선을 제어
- 비상 시 수동 동작이 가능하도록 16개의 스위치와 전체 스위치 탑재
- 수동 동작 중이더라도 발화 층에 대해서는 LED가 점멸하여 쉽게 구분 가능
- 16층 이상일 경우 개수를 늘릴 수 있도록 연결 단자 탑재
- Control the lines of ignition floor and right upper floor by 16 channels of automatic fire detection
- 16 individual buttons and 1 all button for manual control
- Link terminal is in rear panel for expanding in case of using in building with more than 16 floors

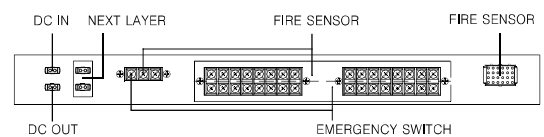
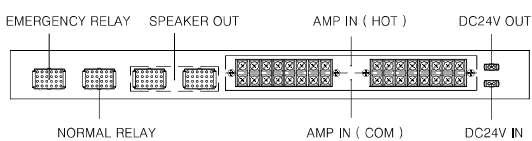

EMERGENCY SPEAKER SWITCHER

ESS-9642



DIRECT SPEAKER SELECTOR

PS-9616



SPECIFICATION	
SPEAKER CONTROL LINE	20 LINES
FIRE DETECTION LINE	20 LINES
AMP INPUT LINE	4 LINES
OUTPUT CONTROL	ALL, GROUP, INDIVIDUAL
POWER SOURCE	DC 24V / 10W
WEIGHT	5kg
DIMENSION	482(W) × 44(H) × 280(D) mm

SPECIFICATION	
SPEAKER CONTROL	16CH
OUTPUT CONTROL	ALL, GROUP, INDIVIDUAL
INDICATING LED	SPEAKER 16CH, GROUP1, GROUP2, ALL
POWER SOURCE	DC 24V
WEIGHT	4kg
DIMENSION	482(W) × 44(H) × 280(D) mm

- 버튼식 스위치로 20회선의 스피커를 임의대로 선택 가능하며, 필요에 따라 전체, 그룹1(CH1~10), 그룹2(CH11~20) 으로 나누어 동작 가능
- 리모트 앰프에서 전체 컨트롤 가능
- 파워 앰프의 REMOTE와 연결하여 RM ALL 방송 및 비상 시 파워 앰프 구동
- 우선 순위에 의한 방송 가능
- 20회선 이상 사용 시 확장을 위한 후면 콘넥터
- 4개의 앰프 입력이 있어 다양한 현장 환경에 대응 가능
- 20 individual line buttons, GROUP1(CH1~10) button, GROUP2(CH11~20) button
- Able to control all by remote amplifier
- By connecting to REMOTE of power amp, able to broadcast all as remotely and operate power amp in emergency
- Broadcast in priority available
- Connector for expanding is embedded in rear panel
- 4 amp inputs enable you to apply in various place

- 버튼으로 16개의 스피커 별로 또는 전체, 그룹1, 그룹2 별로 동작 가능
- 표시 LED가 있어 스위치 켜짐/꺼짐 식별 용이
- 매트릭스 (PX-9600)과 같이 사용하는 경우 시스템의 동작 상태를 타이머, 원격 제어의 표시 LED로 쉽게 확인 가능
- 16 individual, ALL, GROUP1, GROUP2 buttons
- Able to know ON/OFF easily by LED indicator
- If using with PX-9600(matrix), able to know the status of system by LED of TIMER and REMOTE

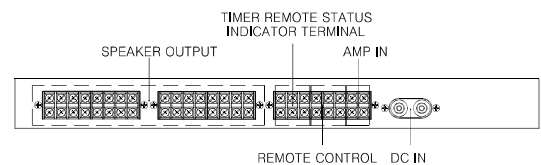
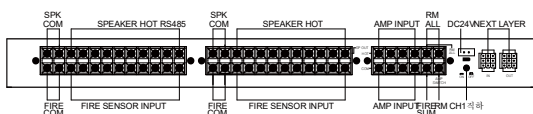

REMOTE EXCHANGER

RE-9600



SPECIFICATION	
REMOTE LINE IN	5CH (BALANCED)
REMOTE LINE OUT	1CH (BALANCED)
REMOTE CONTROL LINE	5 LINES
POWER SOURCE	DC 24V
WEIGHT	2.8kg
DIMENSION	482(W) × 44(H) × 280(D) mm

- 여러대의 리모트 앰프를 연결하여 사용 가능
- 우선 순위에 의하여 RM1 > RM2 > RM3 > RM4 > RM5 으로 동작
- 5개 채널의 REMOTE LINE IN과 1개 채널의 REMOTE LINE OUT으로 구성
- Able to connect many remote amplifiers
- Operate in priority as RM1 > RM2 > RM3 > RM4 > RM5
- 5 channels of REMOTE LINE IN and 1 channel of REMOTE LINE OUT

REMOTE PAGING MICROPHONE

RM-9616



SPECIFICATION	
SPEAKER CONTROL LINE	16 LINES
OUTPUT CONTROL	ALL, INDIVIDUAL
POWER SOURCE	DC 24V
WEIGHT	2kg
DIMENSION	232(W) × 53(H) × 200(D) mm

- 시스템의 스피커 회선을 개별 또는 전체로 컨트롤 가능
- 고감도 콘덴서 마이크에 의해 높은 명료도의 방송 가능
- 별도의 선택 스위치 조작 없이 TALK 스위치를 ON하여 방송 가능
- 4음계 차임이 있어 방송 전, 후 사용 가능
- 리모트 앰프가 설치된 장소에서 카세트 데크, 튜너, CD플레이어 등을 연결하여 사용 가능
- Able to control individual or all channels of system remotely
- High sensitivity condenser mic enables clear broadcast
- 4 tone chime for start or end of broadcast
- Able to connect source devices such as casset deck, tuner, CD player

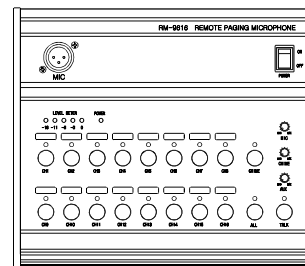
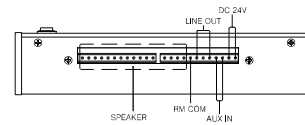
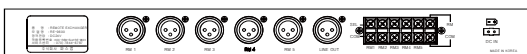

AMPLIFIER

DPA-300/400/500/600	Digital Power Amplifier	44
PA-9612/9624/9636/9648	Analog Power Amplifier	45

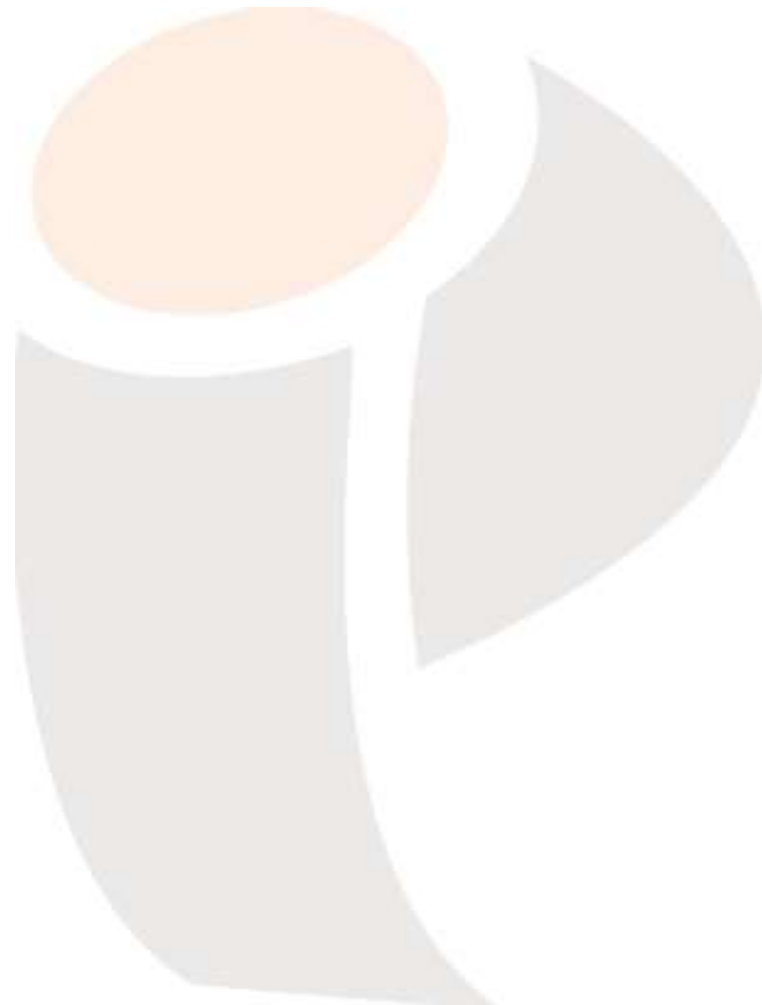

DIGITAL POWER AMPLIFIER

DPA-300/400/500/600



SPECIFICATION	DPA-300	DPA-400	DPA-500	DPA-600
RATED OUTPUT	300W	400W	500W	600W
INPUT SENSITIVITY / IMPEDANCE	1V/22k Ω , BAL			
OUTPUT VOLTAGE / IMPEDANCE	70V/16.5 Ω 100V/33 Ω	70V/12.5 Ω 100V/25 Ω	70V/10 Ω 100V/20 Ω	70V/8 Ω 100V/16 Ω
FREQUENCY RESPONSE	80Hz~18KHz			
T.H.D	$\leq 1\%$			
S/N	$\geq 90\text{dB}$			
POWER SOURCE	AC 220V / 60Hz, DC 24V			
POWER CONSUMPTION	82W	101W	120W	139W
WEIGHT	6.6kg	6.6kg	7.2kg	7.2kg
DIMENSION	482(W) \times 44(H) \times 320(D) mm			

- 효율 80% 이상의 뛰어난 성능
 - SMPS 전원 및 디지털 증폭 방식을 사용하여 경량화 추구
 - AC/DC SMPS 가 내장되어 정전 시에도 비상 전원을 연결하여 비상 방송 가능
 - 70V, 100V 출력 선택 가능
 - 400Hz HPF ON/OFF 스위치 내장
 - 과부하 또는 출력 라인 쇼트 보호, DC 전압 보호 회로, 온도 상승 보호 회로가 내장되어 높은 신뢰도 보장
- efficient performance with more than 80%
 - Using SMPS power and digital way for compact size and weight
 - AC/DC SMPS enables emergency broadcast in blackout
 - Able to select 70V or 100V
 - ON/OFF switch for 400Hz HPF
 - Protection circuit is embedded for overheat, voltage, and short

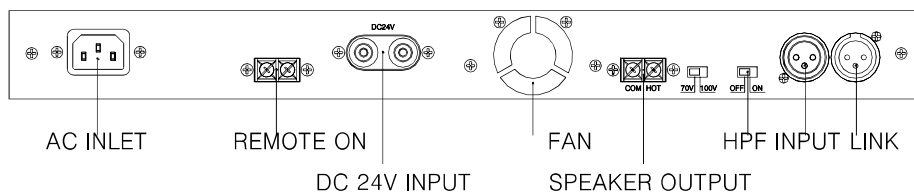

ANALOG POWER AMPLIFIER

PA-9612/9624/9636/9648



SPECIFICATION	PA-9612	PA-9624	PA-9636	PA-9648
RATED OUTPUT	120W	240W	360W	480W
INPUT SENSITIVITY / IMPEDANCE	1V/10kΩ, BAL			
OUTPUT VOLTAGE / IMPEDANCE	22V/4Ω 31V/8Ω 70V/42Ω 100V/83Ω	31V/4Ω 43.8V/8Ω 70V/21Ω 100V/42	38V/4Ω 53.5V/8Ω 70V/14Ω 100V/28Ω	43.8V/4Ω 70V/10.2Ω 100V/20.8Ω
FREQUENCY RESPONSE	70Hz~18KHz			
T.H.D	≤1%			
S/N	≥85dB			
HPF (400Hz)	1.5dB			
POWER SOURCE	AC 220V / 60Hz, DC 24V			
POWER CONSUMPTION	310W	800W	1100W	1450W
WEIGHT	14kg	19kg	21kg	22kg
DIMENSION	482(W) × 132(H) × 280(D) mm			

- 저잡음 고효율 회로
- 신뢰도 높은 부품을 사용하여 고장 없이 오랜 기간 사용 가능
- 메인 히트 싱크에 서미스터를 부착하여 과열 시 이를 감지하여 출력 OFF
- 비상 기기와 연동하여 동작할 수 있는 REMOTE 단자
- Minimized noise and high performance circuit
- Made with reliable parts for long time use
- Thermister on main heat sink senses overheat and automatically cuts off the output
- REMOTE terminal for connecting with emergency unit

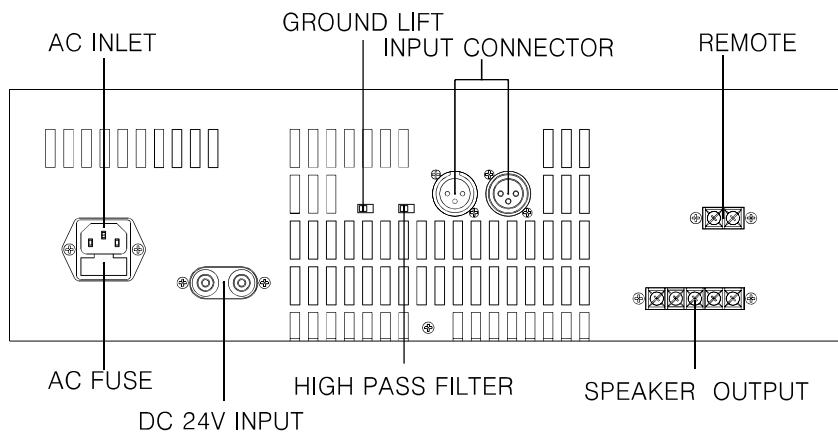

COMMON UNIT

AD-9600	Audio Distributor	48
BK-9610/9620/9630	Blank Panel	48
BC-9600	Battery Charger	49
BC-9660	Battery Charger	49
EM-9600V	Emergency Unit (V1)	50
PD-9600	Power Distributor	50
PDC-9600	Power Distributor Controller	51
PF-9600	Auto Blower	51
PG-9600	Progrem Exchanger	52
PMP-3100	Monitor Panel	52
PP-9600	Pre Amplifier	53
PP-9620	Pre Amplifier	53
PEX-4	Emergency Exchanger	54
TB-9616/9632	Terminal Board	54

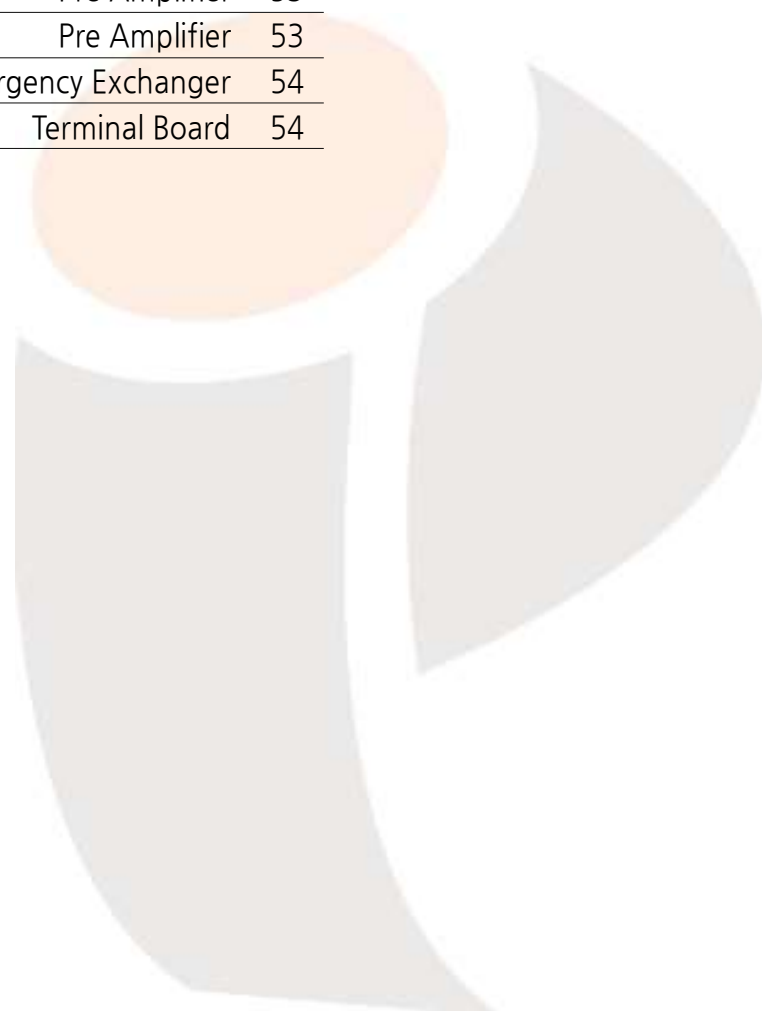

AUDIO DISTRIBUTOR

AD-9600



SPECIFICATION	
OPERATING METHOD	MANUAL
INPUT	2 LINES
INPUT	4 LINES/8 LINES
INDICATOR	OUTPUT P.P LED
POWER SOURCE	DC 24V
WEIGHT	4kg
DIMENSION	482(W) × 44(H) × 280(D) mm

- 모노, 스테레오 선택 출력 가능
- 각 출력 채널에 LED로 표시
- 음량 조절 가능
- 입력 및 출력 회로에 전자 밸런스 회로를 채택하여 잡음 유입 방지
- Able to select MONO or STEREO
- Indicate by LED for each output channel
- Balanced circuit is used for preventing noise while input and output

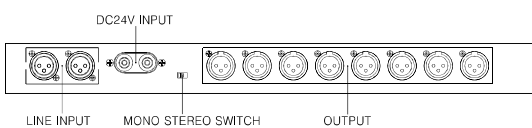

BLANK PANEL

BK-9610/9620/9630



SPECIFICATION	BK-9610	BK-9620
DIMENSION	482(W) × 44(H) × 280(D) mm	482(W) × 88(H) × 280(D) mm
SPECIFICATION	BK-9610	
DIMENSION	482(W) × 132(H) × 280(D) mm	

- 랙시스템의 빈 공간을 채워 깔끔한 외관 선사
- 열 방출 공간을 확보하여 시스템 안전성 증가
- Fill the empty space of rack type PA system for clean looking
- Space makes system safer to let heat goes out easily

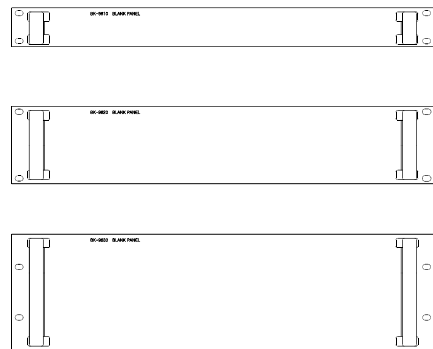

BATTERY CHARGER

BC-9600



SPECIFICATION	
POWER SOURCE	AC 220V, 60Hz
CHARGING START VOLTAGE	ALWAYS
CHARGING END VOLTAGE	DC 27.3V
WEIGHT	6.5kg
DIMENSION	482(W) × 88(H) × 280(D) mm

- 랙시스템에 비상 전원 공급을 위한 배터리를 충전하는 기기
- 충전 시 3A 전류로 충전되며 충전이 다 됐을 경우 10mA~20mA로 감소하여 만충을 유지
- Unit for charging the battery which is used for blackout
- Charging at 3A, and lower the current to 10mA~20mA when the battery is fully charged

BATTERY CHARGER

BC-9660



SPECIFICATION	
POWER SOURCE	AC 220V, 60Hz
CHARGING START VOLTAGE	ALWAYS
CHARGING END VOLTAGE	DC 30V
WEIGHT	8kg
DIMENSION	482(W) × 132(H) × 280(D) mm

- 랙시스템에 비상 전원 공급을 위한 배터리를 충전하는 기기
- 충전 시 배터리 전압이 27.6V 이하일 경우 10A로 급속 충전
- 배터리 전압이 27.6V가 되면 1A로 전류량을 낮추어 충전
- 배터리 전압이 30V가 되면 만충전 상태로 판단하여 100mA로 낮추어 충전 상태 유지
- Unit for charging the battery which is used for blackout
- When battery's voltage is lower than 27.6V, charging at 10A for quick charge
- When battery's voltage reaches to 27.6V, charging at 1A
- When the battery's voltage reaches to 30A, charging at 100mA to maintain full charge

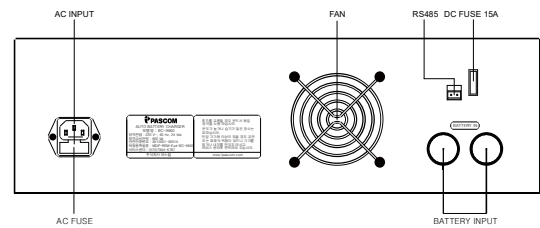
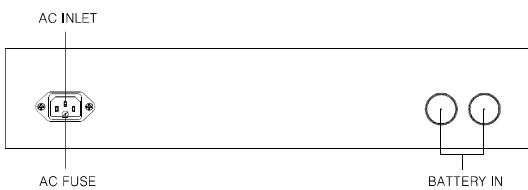

EMERGENCY UNIT (V1)

EM-9600V



SPECIFICATION	
OPERATING METHOD	AUTO, TEST
SIREN FREQUENCY	800Hz (Wave)
MICROPHONE	Uni-direction dynamic
PROGRAM EXCHANGE	Normal broadcast, REMOTE2, REMOTE1, Timer, EXT2, EXT1, Emergency broadcast
WEIGHT	6.5kg
DIMENSION	482(W) × 88(H) × 280(D) mm

- 화재 자동 감지기와 연결하여 화재 자동 경보 송출
- 점검 및 시험 운영을 위한 스위치 탑재
- 외부 장비 또는 자동 방송장치와 연결하여 무인 방송 가능
- 화재 대피 안내 방송 4개 국어 (한국어, 영어, 일본어, 중국어) 중 선택하여 사용 가능
- Automatic emergency broadcast by connecting with a fire detector
- Switch for testing operation
- Unmanned broadcasting is possible by connecting to external equipment or automatic broadcasting devices.
- 4 language; Korean, English, Japanese, Chinese selectable

POWER DISTRIBUTOR

PD-9600



SPECIFICATION	
INPUT/OUTPUT CHANNEL	16CH
FUSE	Normally 500mA
POWER SOURCE	DC 24V
POWER CONSUMPTION	1W
WEIGHT	4.3kg
DIMENSION	482(W) × 132(H) × 280(D) mm

- 랙시스템의 전원 제어
- AC OUTLET 단자가 있어 편리한 사용 가능
- 정전 시에도 시스템을 동작하기 위한 배터리 전원 입력 기능이 있어 항상 직류 정격 24V 전원 출력
- 랙시스템 본체의 전원이 OFF 되어 있는 상태에도 원격 조정으로 시스템 제어 가능
- LED 세그먼트를 사용하여 정확도 향상
- Control the power of PA system
- AC OUTLET terminal for convenient use
- Always output DC 24V for battery to operate a system in blackout
- Able to control a system remotely even if the system's power is off
- LED segment for accuracy

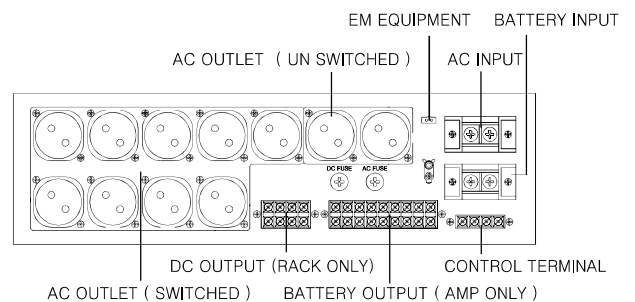
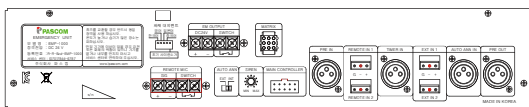

POWER DISTRIBUTOR CONTROLLER

PDC-9600



SPECIFICATION	
IN/OUT CHANNEL	Total 8CH
OPERATING SENSITIVITY	30mV (Changeable by sensitivity controller in front)
POWER CONSUMPTION	2W
POWER SOURCE	DC 24V
WEIGHT	3kg
DIMENSION	482(W) × 44(H) × 280(D) mm

- PD-9600의 REMOTE ON 단자에 연결하여 오디오 신호가 있을 시에만 동작하게 하여 소모 전력 저감
- 총 8개의 오디오 라인 입력력 중 하나라도 30mV 정도의 오디오 신호가 입력되면 후면부 접점 쇼트
- It supports PD-9600(power distributor) operates only when audio signal is in, which enables to reduce power consumption
- If any line among 8CH audio lines gets around 30mV input, the contact in rear is shorted

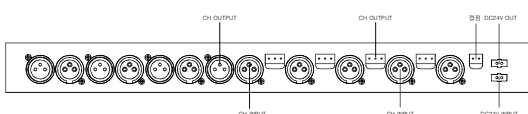

AUTO BLOWER

PF-9600



SPECIFICATION	
OPERATION	OFF, MANUAL, AUTO
FAN STARTING TEMP (AUTO)	≥38°C
POWER SOURCE	DC 24V
CURRENT CONSUMPTION	240mA (MAX)
RPM	2600RPM
MAXIMUM AIR FLOW	2.33m ³ /min
SOUND NOISE	40dBA
WEIGHT	1.4kg
DIMENSION	482(W) × 132(H) × 39(D) mm

- PA시스템의 내부 온도 상승 시 자동으로 팬이 동작하여 시스템의 열 상승을 방지
- 고감도 온도 감지 소자를 사용하여 우수한 온도 감지 능력
- 저소음 팬을 사용하여 2개의 팬이 고속으로 회전하여도 거의 발생하지 않는 소음
- Fans automatically operates when the temperature of PA system is high
- Excellent in sensing temperature
- Made with high quality fan for minimizing the noise

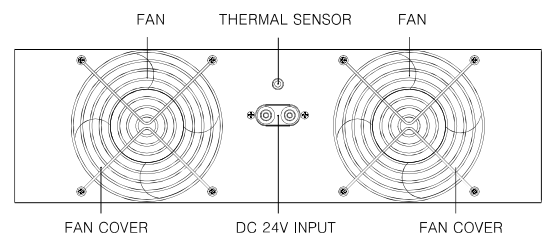

PROGRAM EXCHANGER

PG-9600



MONITOR PANEL

PMP-3100



SPECIFICATION	
HOW TO OPERATE	AUTO
PGM EXCHANEL	4CH
DISPLAY	LED
POWER SOURCE	DC 24V
WEIGHT	4.8kg
DIMENSION	482(W) × 44(H) × 280(D) mm

- 일반 방송 및 BGM 동작중 REMOTE, TIMER, 비상 방송 등이 입력 될 때 자동으로 신호 전환
- 우선 순위가 낮은 신호를 차단하고 빠른 신호가 출력되도록 전환 (EM > TIMER > RM1 > RM2)
- 입력 4회로, 출력 4회로로 구성
- 어떤 신호가 방송되고 있는지 LED로 식별 가능
- Automatically switches signals when remote, timer, or emergency broadcasts are input during regular broadcasts and BGM operation.
- Cut off the low priority's signal, and exchange to high priority's signal
- 4 input lines and 4 output lines
- Able to see which signal is being broadcast by LED

SPECIFICATION	
EXTERNAL INPUT	8CH 100V INPUT
LED MONITOR OUTPUT	8CH at once
MONITOR SPEAKER OUTPUT	5W
POWER SOURCE	DC 24V
WEIGHT	3.8kg
DIMENSION	482(W) × 88(H) × 280(D) mm

- 각 출력을 LED 미터로 표시하며, 랙 전체의 출력 레벨 확인 가능
- 8대의 파워 앰프의 각 출력 레벨 확인 및 모니터링 가능
- 고품질 스피커를 사용하여 명료하고 풍부한 음량
- 음량 조절 기능
- Indicate every channel's output status by LED meter
- Able to check and hear the output sound of every 8CH's amplifier
- High-power speaker gives rich sound

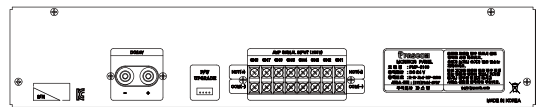
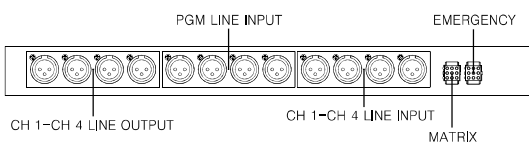

PRE AMPLIFIER

PP-9600



SPECIFICATION	
T.H.D	≤0.5%
FREQUENCY RESPONSE	40Hz~18kHz
TONE CONTROL	BASS : 100Hz±12dB TREBLE : 10kHz±12dB
S/N	≥70dB
INPUT SENSITIVITY / IMPEDANCE	MIC 1~3 : 1mV/600Ω(BAL) Tuner, Deck, AUX, Chime : 200mV/47kΩ(UNBAL) CD : 1V/47kΩ(UNBAL)
OUTPUT LEVEL / IMPEDANCE	REC OUT : 500mV/1kΩ LINE OUT : 1.2V/600Ω
POWER SOURCE	AC 220V/60Hz, DC 24V
WEIGHT	3.5kg
DIMENSION	482(W) × 44(H) × 280(D) mm

- 다양한 입력 단자들의 신호를 믹싱 가능
- 입, 출력 신호 유입 시 발생할 수 있는 잡음을 방지하기 위하여 마이크1~3, 라인 출력 회로 발란스 처리
- Able to mix the signal of various kinds of inputs
- Balance the circuit of MIC1~3 and LINE output to prevent noise that may be caused while input and output

PRE AMPLIFIER

PP-9620



SPECIFICATION	
RATED OUTPUT	MASTER OUTPUT : ±4dBm/600Ω, BAL Sub 1,2 OUTPUT : ±4dBm/600Ω, UNBAL REC OUTPUT : -10dBV/10kΩ, UNBAL
INPUT SENSITIVITY / IMPEDANCE	MIC (CH1~CH9) : -60dBm/600Ω, BAL LINE (CH1~CH6) : -20dBm/47kΩ, BAL LINE (CH7~CH9) : -20dBm/47kΩ, UNBAL AUX1,2 : -10dBm/20kΩ, UNBAL PRIORITY 1,2 : 0dBm/20kΩ, UNBAL INSERT : 0dBm/20kΩ, UNBAL
INPUT CHANNEL EQ	High (10kHz) : ±12dB Mid (1kHz) : ±12dB Low (100Hz) : ±12dB
OUTPUT CHANNEL EQ	High (10kHz) : ±12dB Hi-Mid (2kHz) : ±12dB Low-Mid (400Hz) : ±12dB Low (80Hz) : ±12dB
RESIDUAL NOISE	≤-90dB
CROSS TALK	≤-60dB
PHANTOM POWER	+18VDC
POWER SOURCE	AC 220V/60Hz, DC 24V
POWER CONSUMPTION	12W
WEIGHT	4.9kg
DIMENSION	482(W) × 88(H) × 280(D) mm

- 9개의 채널 입력, 1개의 마스터 출력, 음량 조절기의 영향을 받지 않는 1개의 녹음 출력 내장
- 각 채널별 독립적 EQ를 통해 사용자의 취향에 따라 음색 조절 가능
- 우선 순위 입력 2채널
- 채널 1번, 2번에서 콘덴서 마이크를 사용할 수 있도록 설계 (전원 : +18V)
- 9CH of individual channel, 1CH of master output, 1CH of record output(Not affected by volume controller)
- Able to control the tone as user's need, by each channel's equalizer
- 2CHs of priority input
- Able to use condenser microphone for CH1 and CH2 (Power : +18V)

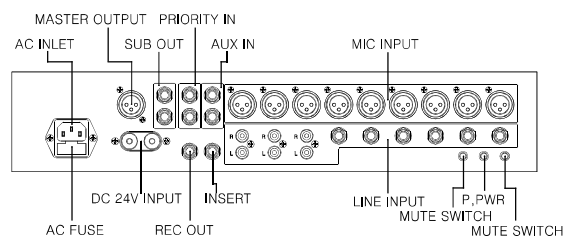
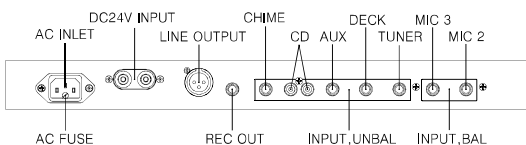

EMERGENCY EXCHANGER

PEX-4



SPECIFICATION	
RATED INPUT	600mV
RATED OUTPUT	2V
S/N	≥85dB
T.H.D	≤0.01%
RATED IN/OUTPUT RATE	1:1
FIRE SIGNAL RECEIPT WAY	BY CONTACT
POWER SOURCE	DC 24V, 500mA
WEIGHT	1kg
DIMENSION	220(W) × 44(H) × 175(D) mm

- 일반방송과 리모트방송, 비상방송 사이에서 전환시켜 주는 장치
- 우선 순위 순서 : 화재 방송 > 리모트 방송 > 일반 방송
- 리모트 입력단자를 통한 리모트 방송 가능
- AMP입력(Signal)을 통한 LOCAL 입력, 외부입력 전환 기능
- 화재접점(무접점)을 통한 비상방송 송출 기능

- Converting audio between normal broadcast and emergency broadcast
- Priority order : emergency broadcast → remote broadcast → normal
- Remote broadcasting is possible through the remote input terminal.
- LOCAL input and external input switching function through AMP input (Signal)
- Emergency broadcast transmission function through fire contact (non-contact)

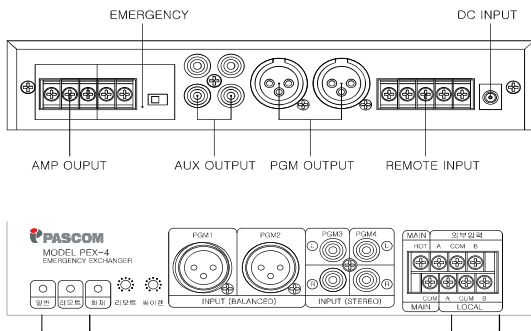

TERMINAL BOARD

TB-9616/9632



SPECIFICATION	TB-9616	TB-9632
LINE	16	32
WEIGHT	1.5kg	2.4kg
DIMENSION	482(W) × 44(H) × 280(D) mm	482(W) × 88(H) × 280(D) mm

- 릴레이그룹과 연결하여 스피커로 출력하는 기기
- 일반방송 2선과 비상방송 1선, 총 3선식으로 각 채널 구성
- Unit for outputting to speakers by connecting with relay group
- 2-line for normal broadcast, 1-line for emergency, total 3-line for each channel

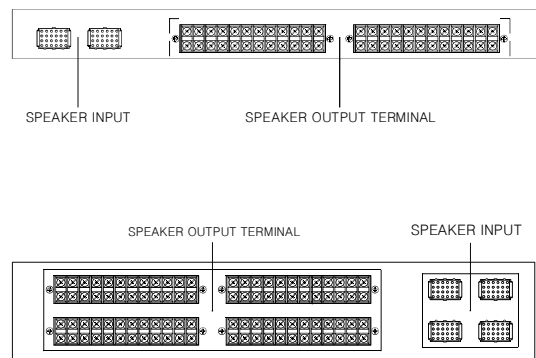

SHORT CIRCUIT PROTECTION

PLC-9616	Speaker Line Checker	56
PLF-9605	Line Fuse Checker	56
PLF-105	1CH Line Checker	57
ST-03/05/08	Line Fuse Checker Board	57
ST-051S/054S	Line Short Checker Board	58
STU-051S/054S	Line Short Checker Board	58

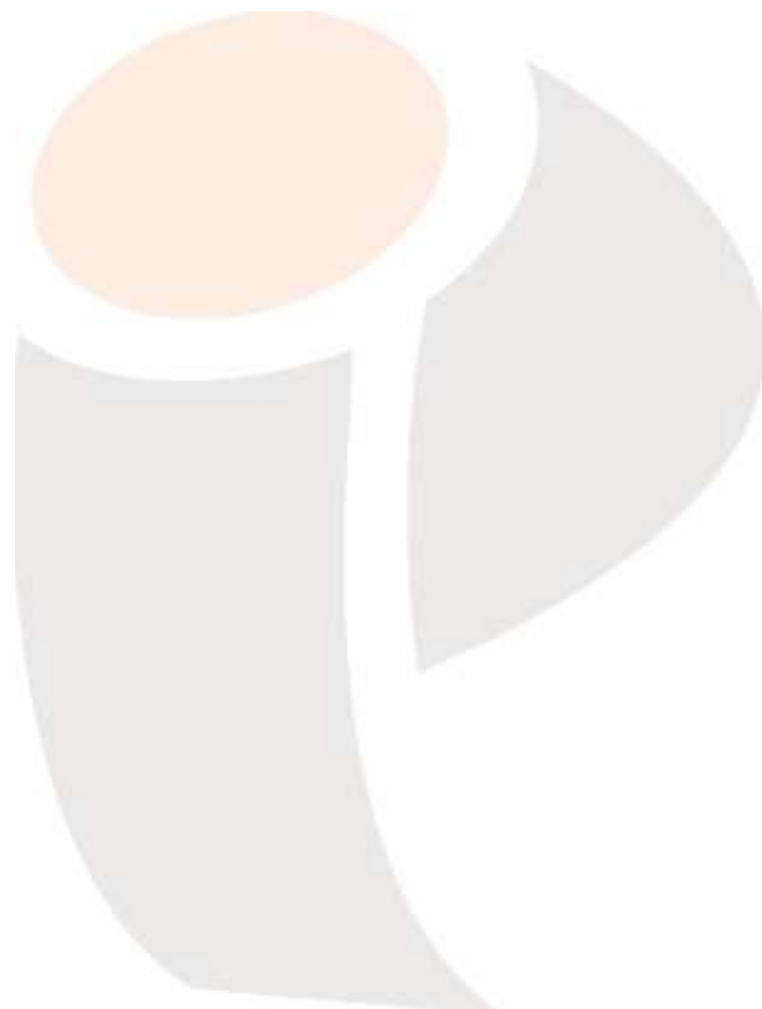

SPEAKER LINE CHECKER

PLC-9616



SPECIFICATION	
CHECKING RANGE	3W~500W(3.3kΩ~20Ω)
CHECKING TIME	≤180msec/CH
SIGNAL INPUT	MAX 16 CH
SIGNAL OUTPUT	MAX 16 CH
ADC DECOMPOSING ABILITY	10 bit (1024 step)
POWER CONSUMPTION	6VA
POWER SOURCE	DC 24V / 500mA
WEIGHT	3.8kg
DIMENSION	482(W) × 44(H) × 280(D) mm

- 선로 단락 시에도 다른 층 화재 방송 유지
- 2선식/3선식 스피커 라인 체크
- 70V/100V 스피커 라인 체크
- 임피던스 체크 (라인 오픈, 오버 임피던스, 언더 임피던스, 라인 쇼트)
- 스피커 라인 접지상태 체크
- 최대 16채널 스피커 라인 체크
- 부저 경고음
- Maintain broadcast to other lines even if one particular line is short-circuited
- 2-wire/3-wire speaker line checking
- 70V/100V speaker line checking
- Impedance checking (line open, over impedance, under impedance, line short-circuit)
- Maximum 16CH speaker line check
- Buzzer function

LINE FUSE CHECKER

PLF-9605



SPECIFICATION	
INPUT/OUTPUT CHANNEL	16CH
FUSE	Normally 500mA
POWER SOURCE	DC 24V
POWER CONSUMPTION	1W
WEIGHT	3kg
DIMENSION	482(W) × 44(H) × 280(D) mm

- 총 16개의 스피커 라인에 과전류에 대응할 수 있는 퓨즈 내장
- 과전류가 흘러 퓨즈가 단선될 경우 해당 라인의 LED가 점등
- 퓨즈 단선 시 부저 경고음이 울려 청각적으로 쉽게 인지 가능
- DC 전원을 사용하므로 랙시스템의 DC 전원 사용 가능
- Built-in fuse for 16 channels in case of overcurrent
- Indicate the short-circuited fuse by LED
- Buzzer sound for indicating short-circuit
- Able to use power from rack system by DC power

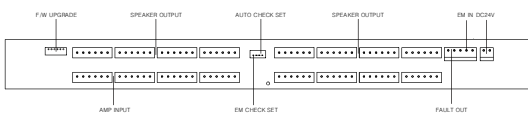

1CH LINE CHECKER

PLF-105



SPECIFICATION	
SWITCH RECOVERY TYPE	PTC
MAXIMUM CAPACITY	1W ~ 20W
OPERATING VOLTAGE	AC 0V ~ 250V
DIMENSION	23.2(W) × 93.4(H) × 23.5(D) mm

- 스피커 선로의 이상 여부를 육안으로 확인할 수 있도록 LED 표시
- 단락시 스위치 휴즈가 해당 선로를 차단
- 직상층 외 다른층의 방송 출력에 이상이 없도록 예방
- LED for checking short-circuited line
- In case of a short circuit, the switch fuse cuts off the corresponding line
- Prevents the output problem of other lines even if one line is short-circuited

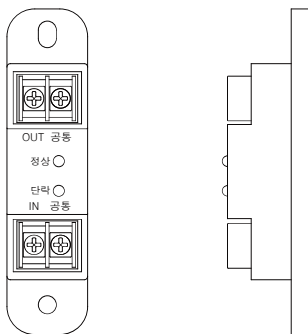

LINE FUSE CHECKER BOARD

ST-03/05/08

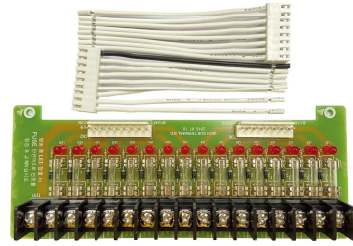

SPECIFICATION	
INPUT & OUTPUT CHANNEL	16CH
FUSE CAPACITY	ST-03 : 300mA
	ST-05 : 500mA
	ST-08 : 800mA

- 화재로 인하여 하나의 스피커 라인이 단선 되어도 다른 라인의 방송에 지장이 없도록 하는 단락 보호 장치
- 앰프 1대의 출력에서 여러 라인으로 분산되는 경우 한 개의 라인 단락 시 단락된 선로의 출력이 작거나 안 되는 것을 방지하기 위하여 설치하는 보드
- 설치 후 단락될 경우 단락 선로만 방송이 출력되지 않고 다른 선로들은 정상적으로 방송이 출력되며 단락 선로가 복구될 경우 휴즈를 교체하면 다시 정상적으로 출력
- LED for checking short-circuited line
- When 1 amplifier spread the output to several lines, you can add this board to prevent the short-circuited line's sound becoming smaller or losing
- If you install this board, only short-circuited line doesn't output but other lines do work normally

LINE SHORT CHECKER BOARD

ST-051S/054S

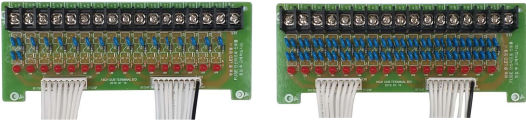

SPECIFICATION	ST-051S	ST-054S
IN/OUTPUT CHANNEL	16CH	
ALLOWED CAPACITY PER CH	B1 CH : MAX 80W / RATED 60W 1F~15F : MAX 30W / RATED 20W	B1~15F : MAX 80W / RATED 60W
MAXIMUM INPUT VOLTAGE	240V AC/DC	
OPERATING TEMPERATURE	-40℃~85℃	
DIMENSION	172(W) × 58(H) × (D) mm	

- 앰프 1대의 출력에서 여러 라인으로 분산되는 경우 한 개의 라인 단락 시 단락된 선로의 출력이 작거나 안 되는 것을 방지하기 위하여 설치하는 보드
- 설치 후 단락될 경우 단락 선로만 방송이 출력되지 않고 다른 선로들은 정상적으로 방송이 출력되며 단락 선로가 복구될 경우 다시 정상적으로 출력
- LED 를 통하여 단락된 선로 확인 가능
- When 1 amplifier spread the output to several lines, you can add this board to prevent the short-circuited line's sound becoming smaller or losing
- If you install this board, only short-circuited line doesn't output but other lines do work normally
- LED indicators let you know which line is short-circuited

LINE SHORT CHECKER BOARD

STU-051S/054S

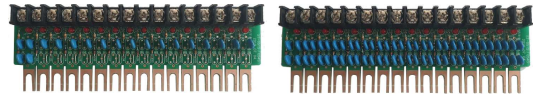

SPECIFICATION	STU-051S	STU-054S
IN/OUTPUT CHANNEL	16CH	
ALLOWED CAPACITY PER CH	B1 CH : MAX 80W / RATED 60W 1F~15F : MAX 30W / RATED 20W	B1~15F : MAX 80W / RATED 60W
MAXIMUM INPUT VOLTAGE	240V AC/DC	
OPERATING TEMPERATURE	-40℃~85℃	
DIMENSION	172(W) × 58(H) × (D) mm	

- 앰프 1대의 출력에서 여러 라인으로 분산되는 경우 한 개의 라인 단락 시 단락된 선로의 출력이 작거나 안 되는 것을 방지하기 위하여 설치하는 보드
- 설치 후 단락될 경우 단락 선로만 방송이 출력되지 않고 다른 선로들은 정상적으로 방송이 출력되며 단락 선로가 복구될 경우 다시 정상적으로 출력
- LED 를 통하여 단락된 선로 확인 가능
- When 1 amplifier spread the output to several lines, you can add this board to prevent the short-circuited line's sound becoming smaller or losing
- If you install this board, only short-circuited line doesn't output but other lines do work normally
- LED indicators let you know which line is short-circuited

SOURCES

CDR-3100	MP3 Recording & CD Player	60
MCD-9600A	Media CD Playe	60
DRT-9600	Digital Radio Tuner	61
DPT-9602	Digital Program Timer	61
DTP-9600	Digital Telephone Paging	62
DC-9600S	Cassette Player	62
PCS-3100	Chime & Siren	63
SV-9600	Event Player	63
ESA-1000	Emergency Situation Announcement(V1)	64
PJS-2030	Joy Song	64

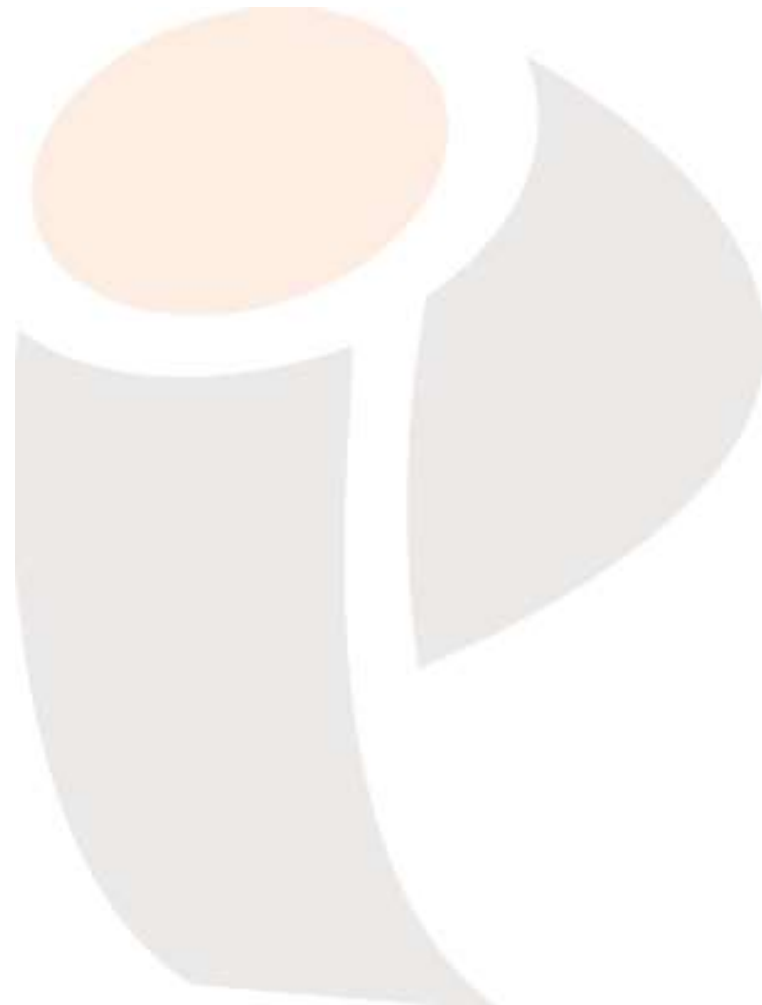

MP3 RECORDING & CD PLAYER

CDR-3100



SPECIFICATION	
RATED OUTPUT	STEREO : 0.7V MONO : 1V
FREQUENCY RESPONSE	20Hz~18KHz
T.H.D	≤0.1%
S/N	≥80dB
CHANNEL SEPARATION	≥60dB
RECORDING INPUT	150mV
POWER CONSUMPTION	10W
POWER SOURCE	AC 220V / 60Hz, DC 24V
WEIGHT	2.7kg
DIMENSION	482(W) × 44(H) × 280(D) mm

- CD/USB/SD카드 플레이어 및 레코딩 기기
- MP3 파일 재생 기능
- 고음질 192kHz, 44kHz 샘플링 녹음 가능
- EM 레코딩 기능
- 마지막 재생 파일을 기억하여 전원을 껐다 켜도 이어서 재생
- 날짜 및 시간 표시
- 지정된 시간동안만 재생 및 정지하는 타이머 기능
- CD/USB/SD player & recorder
- MP3 playing
- High quality sound (192kHz), 44kHz sampling available
- EM recording function
- Memorize the last file you played even if power is off and resume when power is on
- Timer for playing or pausing on particular time

MEDIA CD PLAYER

MCD-9600A



SPECIFICATION	
RATED OUTPUT	2V
FREQUENCY RESPONSE	20Hz~20KHz
T.H.D	≤0.1%
POWER CONSUMPTION	10W
POWER SOURCE	AC 220V / 60Hz, DC 24V
WEIGHT	2.6kg
DIMENSION	482(W) × 44(H) × 280(D) mm

- DVD, CD, HDCD, VCD, SVCD, MP3 파일, AVI 파일, JPG 파일 등 재생 가능
- CD-R, DVD-R, DVD+R, USB, USB 외장하드 등 지원
- 오디오 : 2.1채널, 5.1채널, Optical 광출력, Coaxial 및 DTS 지원
- 비디오 : Composite(AV), Component YPbPr(YCbCr, YUV), S-Video, VGA, HDMI 지원
- Can play DVD, CD, HDCD, VCD, SVCD, MP3 file, AVI file, JPG file, etc.
- Supports CD-R, DVD-R, DVD+R, USB, etc.
- Audio : 2.1CH, 5.1CH, Optical Power, Coaxial, DTS
- Video : Composite(AV), Component YPbPr(YCbCr, YUV), S-Video, VGA, HDMI

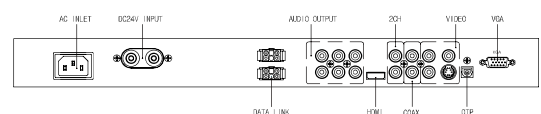
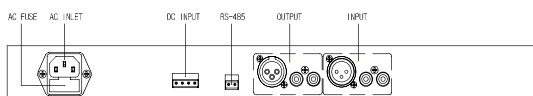

DIGITAL RADIO TUNER

DRT-9600



SPECIFICATION	
RATED OUTPUT	600mV / 600Ω
FREQUENCY RESPONSE	FM : 80Hz ~ 12KHz / AM : 125Hz ~ 1.8KHz
T.H.D 1KHz	FM : ≤0.2% / AM : ≤1%
S/N	FM : ≥60dB / AM : ≥50dB
TUNING RANGE	FM : 87.5MHz ~ 108MHz / AM : 552KHz ~ 1611KHz
FREQUENCY STEP	70Hz ~ 9KHz
SENSITIVITY	FM : 10dB / AM : 30dB
AUTO STOP	FM : 29dB / AM : 20dB
POWER SOURCE	AC 220V / 60Hz, DC 24V
POWER CONSUMPTION	12W
WEIGHT	3.5kg
DIMENSION	482(W) × 44(H) × 280(D) mm

- 고감도 FRONT END를 채택하여 우수한 수신 감도
- FM 30개국, AM 30개국 총 60개의 방송 메모리 가능
- 전면 패널의 SEEK UP, DOWN 버튼을 눌러 자동 방송 동조
- 음소거 회로 내장으로 국 간의 잡음을 제거기능
- 모노 또는 스테레오 출력
- High sensitivity front end enables an excellent receipt
- Able to memorize 30 frequencies for each FM and AM (Total 60)
- Automatically synchronize the frequency once pusing SEEK UP or DOWN in front panel
- Built-in mute circuit to eliminate inter-channel noise
- Mono or stereo output.

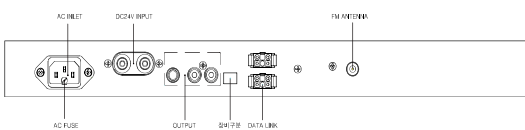

DIGITAL WEEKLY PROGRAM TIMER / V1

DPT-9602



SPECIFICATION	
RATED OUTPUT	1V
COMMUNICATION METHOD	2400bps, RS-485
EXTERNAL INPUT	AUDIO INPUT 4CH
SOURCES PLAY	USB
DISPLAY	FND, LED
AC POWER OUTPUT	500W (MAX)
POWER SOURCE	AC 220V / 60Hz, DC 24V
POWER CONSUMPTION	5W
WEIGHT	4kg
DIMENSION	482(W) × 88(H) × 280(D) mm

- Timer, BGM, AC 전원 및 리코트 접점 출력 예약 기능
- 기본 멜로디, 국민의례용, 병원 안내 방송용, 공장 안내 방송용 학교용 총 54개 음원 내장
- 버튼 예약 및 PC 프로그램을 통한 예약 기능
- 500W AC 전원 출력 제어 기능
- 데이터 보존 회로 내장
- 1일 기준 최대 1440개 예약 기능
- Timer, BGM, AC power, and remote contact output reservation functions
- Various melodies built-in
- Button reservation and reservation function via PC program
- 500W AC power output control function
- Built-in data retention circuit
- Up to 1,440 reservations per day

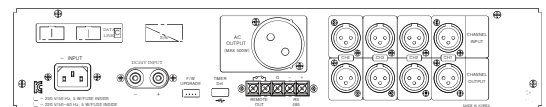

DIGITAL TELEPHONE PAGING

DTP-9600



SPECIFICATION	
FREQUENCY RESPONSE	70Hz~9kHz
CONTROL RANGE	PRX-3100, DRG-9600, DMC-9600SE, EM-9600V
T.H.D	≤1%
S/N	≥60dB
LINE OUT	BALANCED 600Ω
COMMUNICATION METHOD	RS-485, 2400bps
EXTERNAL CONTROL	No contact 16CH, ALL 1CH
DISPLAY	LED
POWER SOURCE	DC 24V / 400mA
WEIGHT	2.4kg
DIMENSION	482(W) × 44(H) × 280(D) mm

- 전화를 통한 페이지징 방송 가능
- ARS 방송 모드와 전화 통화 방송 모드 중 선택 가능
- 비정상적으로 끊겼을 경우 자동으로 연결 해제
- ARS 생략 기능이 있어 긴급 방송 필요 시 생략 후 신속히 방송 가능
- DATA LINK 기능으로 당사의 디지털 전관방송과 연동하여 제어 가능
- 보안을 위해 비밀번호 등록 가능
- Unit for paging broadcast by phone
- Able to select between ARS broadcast mode and phone call broad-cast mode
- Automatically end up the paging when a call is disconnected in abnormal way
- Able to omit ARS function for urgent broadcast
- Able to connect PASCOM's digital PA system by DATA LINK
- Password setting for security

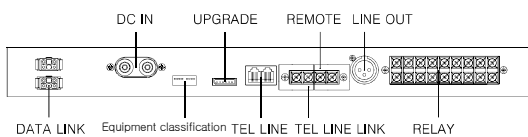

CASSETTE PLAYER

DC-9600S



SPECIFICATION	
RATED OUTPUT	1V
S/N	50dB
FREQUENCY RESPONSE	125Hz~6.3kHz (±3dB)
POWER CONSUMPTION	22W
TRACK SYSTEM	4 track 2CH mono, stereo record/play(DECKA/B)
RECORDING SYSTEM	AC bias system
TAPE SPEED	4.76cm/sec
POWER SOURCE	AC 220V / 60Hz, DC 24V
WEIGHT	4.3kg
DIMENSION	482(W) × 132(H) × 280(D) mm

- 전 기능이 마이크로 프로세서에 의해 이루어져 편리하고 정확한 사용
- 앞, 뒷면 한꺼번에 재생 및 복사 가능
- 데크A와 데크B의 양방향 더빙 가능
- 앞, 뒷면 연속 재생 가능
- 무신호 녹음 기능
- 전원 공급 시 자동적으로 녹음 또는 재생이 되는 타이머 기능
- All functions are based on micro processor
- Able to play or copy both sides of tape
- Two-way dubbing available for both A and B deck
- Able to playback both sides of tape
- No signal recording function
- Timer function enables to record or play automatically once the power is on

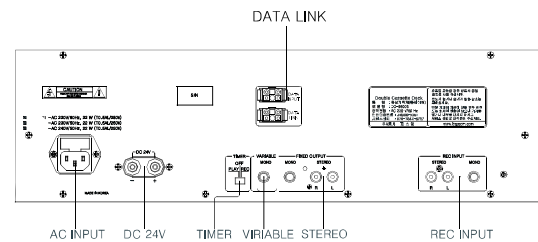

CHIME & SIREN

PCS-3100



SPECIFICATION	
SIREN FREQUENCY	440Hz
CHIME & SIREN OUTPUT LEVEL	660mV, UNBALANCED
POWER SOURCE	DC 24V
WEIGHT	2.8kg
DIMENSION	482(W) × 44(H) × 280(D) mm

- 상향 및 하향 차임과 평탄 및 파상 레벨의 사이렌 내장
- 4음계의 차임으로 방송 시작과 방송 종료 시 신호음으로 사용
- 사이렌은 평탄과 파상 중 선택할 수 있어 비상 또는 각종 훈련 경보로 사용 가능
- Ascending chime for the beginning of a broadcast, and descending chime for the end of a broadcast
- 4 tone chime
- Able to select between flat siren and wave siren for various kinds of emergency cases

EVENT PLAYER

SV-9600



SPECIFICATION	
COMMUNICATION METHOD	19200bps, RS-232
CONTROL RANGE	DPT-9602
EXTERNAL CONTROL	Contact 1CH, external contact playing 10CH
DISPLAY	FND, LED
FREQUENCY RESPONSE	60Hz~18kHz
SOURCE OUTPUT	Stereo 1V(±100mV) / BALANCE 2V(±200mV)
S/N	≥80dB
T.H.D	≤0.01%
POWER SOURCE	DC 24V / 100mA
WEIGHT	2.2kg
DIMENSION	482(W) × 44(H) × 280(D) mm

- 다양한 장소에서 사용되는 행사곡, 음원을 손쉽게 선택하여 즉시 재생 가능
- 여러 개의 음원 파일을 SD카드에 저장하여 배경 음악으로 재생 가능
- 후면 10개의 외부 접점을 이용하여 10개의 음원을 원격지에서 재생 가능
- 외부 PC에서 음원 재생 가능
- Able to select the file for particular event for various places
- Able to save many files in SD card for BGM
- Able to play 10 files remotely by 10 external contacts in rear
- Able to play sources from PC

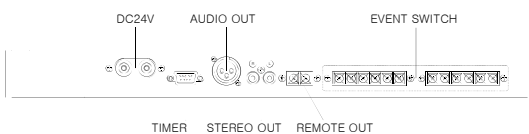

EMERGENCY SITUATION ANNOUNCEMENT / V1

ESA-1000



SPECIFICATION	
LINE OUT	600mV / BALANCE
COMMUNICATION METHOD	CAN
SENSOR INPUT	CONTACT METHOD / RS-485
SENSOR INPUT CHANNEL	16CH
DISPLAY	LED
POWER SOURCE	DC 24V
WEIGHT	2.8kg
DIMENSION	482(W) × 44(H) × 280(D) mm

- 화재 / 재난 비상 자동 방송 음원 송출에의한 대피 유도 기능
- 음원 편집, 제작 사용 가능
- USB 메모리 사용으로 음원 변경 가능
- PC 운영시스템 장애 대응 기능
- Evacuation guidance function through automatic fire/disaster emergency broadcast sound transmission
- Available for audio editing and production
- You can change the sound source using a USB memory stick.
- PC operating system failure response function

JOY SONG

PJS-2030



SPECIFICATION	
RATED POWER	3W / 8Ω
S/N	≥95dB
SENSOR	PIR Sensor
AUDIO FORMAT	MP3 / WAM
STORAGE	SD CARD / MMC (2GB~32GB)
POWER SOURCE	DC 24V, 1A / Adaptor : AC 220V, 60Hz
DIMENSION	482(W) × 44(H) × 280(D) mm

- 인체 감지센서를 통한 자동 음원 플레이 기능
- LINK IN/OUT 단자를 인체 감지센서(PJS-2030M) 확장 가능
- 인체 감지센서를 통한 스위치 접점 기능
- 전관방송과 연동하여 일반방송이나 비상방송시 BGM 제어 기능
- 기기의 동작시간 설정 기능
- 음량 및 센서 감도 조절 기능
- Automatic sound playback function using human body detection sensor
- LINK IN/OUT terminal can be expanded to include a human body detection sensor(PJS-2030M)
- Switch contact function through human body detection sensor
- BGM control function for general or emergency broadcasts in conjunction with the public address system
- Device operating time setting function
- Volume and sensor sensitivity adjustment functions

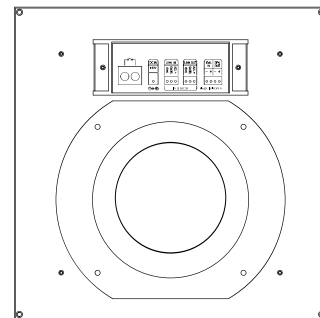

WIRELESS SYSTEM

PWR-951	1CH Wireless System	66
PWR-952	2CH Wireless System (HALF)	66
PWR-962	2CH Wireless System (FULL)	67
H-50	Handheld Microphone	67
B-50	Beltpack Microphone	67
HS-12	Headset for Beltpack Microphone	67
WAD-08	Antena Distributor	68
PWR-AT	Antena	68
PWR-ATD	Antena	68

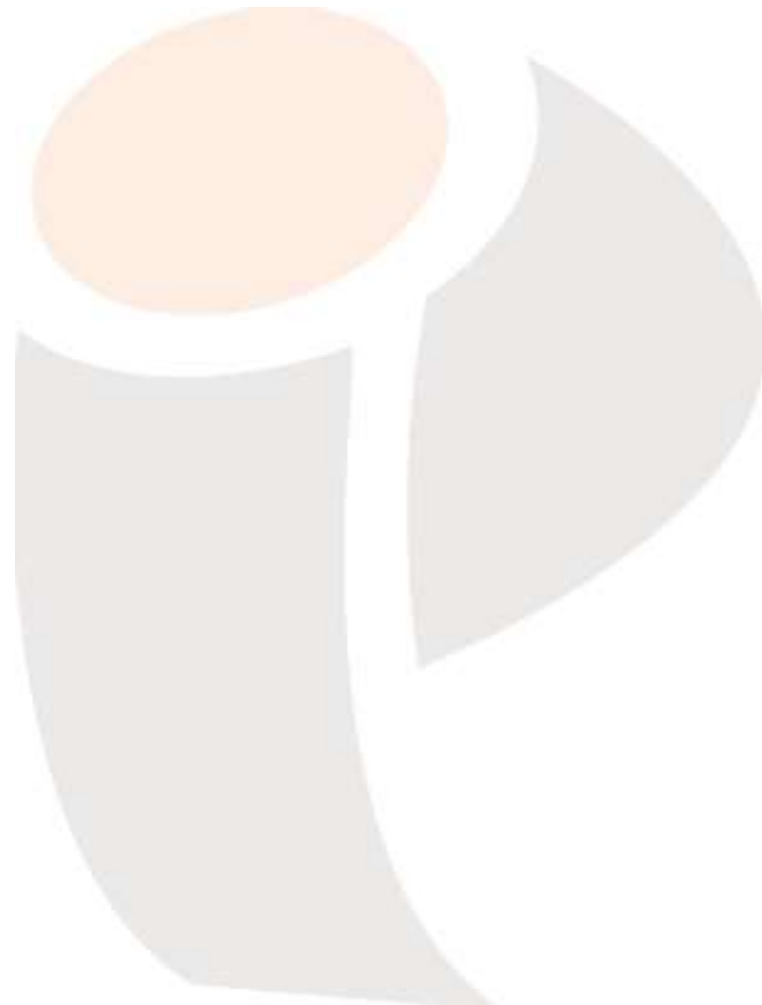

1CH WIRELESS SYSTEM

PWR-951 + 1 MIC (HAND OR BELT)



2CH WIRELESS SYSTEM (HALF)

PWR-952HB + 2 MIC (HB / HH / BB)



SPECIFICATION	
FREQUENCY RANGE	925.00~937.50MHz
OSCILLATION MODE	PLL Synthesized
FREQUENCY STABILITY	±10ppm
MODULATION	FM
OUTPUT POWER	10-30mW
FREQUENCY RESPONSE	40Hz~18kHz
T.H.D	≤0.5%
POWER SOURCE	AC 220V / 60Hz (Adaptor DC 12V 2A)
WEIGHT	Variable acc. composition
DIMENSION	210(W) × 44(H) × 176(D) mm

SPECIFICATION	
FREQUENCY RANGE	925.00~937.50MHz
OSCILLATION MODE	PLL Synthesized
FREQUENCY STABILITY	±10ppm
MODULATION	FM
OUTPUT POWER	10-30mW
FREQUENCY RESPONSE	40Hz~18kHz
T.H.D	≤0.5%
POWER SOURCE	AC 220V / 60Hz (Adaptor DC 12V 2A)
WEIGHT	Variable acc. composition
DIMENSION	210(W) × 44(H) × 176(D) mm

- 트루 다이버시티 회로 및 PLL 시스템을 채택하여 전송 안정성 확보
- IR 동기화 방식으로 사용이 편리
- 자동 주파수 스캔 기능으로 전파 방해 받지 않는 주파수를 신속히 찾아 자동 설정
- 이중 부스트 회로를 탑재하여 배터리가 낮을 때에도 트랜스미터에 영향이 없도록 설계
- 간단한 동작 인터페이스 및 버튼 배치
- 강의 또는 노래를 위한 고감도 마이크팩 사용

- 트루 다이버시티 회로 및 PLL 시스템을 채택하여 전송 안정성 확보
- IR 동기화 방식으로 사용이 편리
- 자동 주파수 스캔 기능으로 전파 방해 받지 않는 주파수를 신속히 찾아 자동 설정
- 이중 부스트 회로를 탑재하여 배터리가 낮을 때에도 트랜스미터에 영향이 없도록 설계
- 간단한 동작 인터페이스 및 버튼 배치
- 강의 또는 노래를 위한 고감도 마이크팩 사용

- True diversity circuit and PLL system for stable transmission
- Designed with IR synchronization for easy use
- Auto scan function finds the stable frequency quickly
- Double boost circuit protects transmitter even if in low battery
- Simple interface and button
- High sensitivity microphone for lecture or sing

- True diversity circuit and PLL system for stable transmission
- Designed with IR synchronization for easy use
- Auto scan function finds the stable frequency quickly
- Double boost circuit protects transmitter even if in low battery
- Simple interface and button
- High sensitivity microphone for lecture or sing

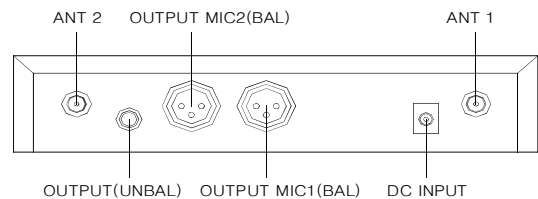
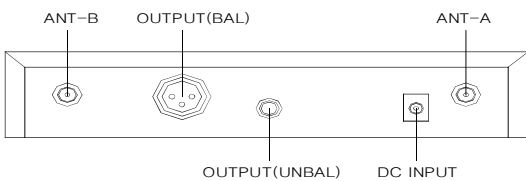

2CH WIRELESS SYSTEM (FULL)

PWR-962 + 2 MIC (HB / HH / BB)



SPECIFICATION	
FREQUENCY RANGE	925.00~937.50MHz
OSCILLATION MODE	PLL Synthesized
FREQUENCY STABILITY	±10ppm
MODULATION	FM
OUTPUT POWER	10-30mW
FREQUENCY RESPONSE	40Hz~18kHz
T.H.D	≤0.5%
POWER SOURCE	AC 220V / 60Hz (Adaptor DC 12V 2A)
WEIGHT	Variable acc. composition
DIMENSION	210(W) × 44(H) × 176(D) mm

- 트루 다이버시티 회로 및 PLL 시스템을 채택하여 전송 안정성 확보
- IR 동기화 방식으로 사용이 편리
- 자동 주파수 스캔 기능으로 전파 방해를 받지 않는 주파수를 신속히 찾아 자동 설정
- 이중 부스트 회로를 탑재하여 배터리가 낮을 때에도 트랜스미터에 영향이 없도록 설계
- 간단한 동작 인터페이스 및 버튼 배치
- 강의 또는 노래를 위한 고감도 마이크팩 사용
- True diversity circuit and PLL system for stable transmission
- Designed with IR synchronization for easy use
- Auto scan function finds the stable frequency quickly
- Double boost circuit protects transmitter even if in low battery
- Simple interface and button
- High sensitivity microphone for lecture or sing

HANDHELD MICROPHONE

H-50



BELTPACK MICROPHONE

B-50



HEADSET FOR BELTPACK MICROPHONE

HS-12

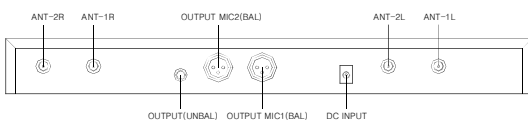

ANTENNA DISTRIBUTOR

WAD-900



ANTENNA

PWR-ATD



ANTENNA

PWR-AT



SPECIFICATION	
NOISE FIGURE	3.7dB (center frequency)
IN / OUT GAIN	1.6dB
ISOLATION	32dB min
ANTENNA GAIN	8dB
OUTPUT VOLTAGE	DC 8V
POWER SOURCE	DC 12V / adapter AC 220V,60Hz
WEIGHT	2.5Kg
DIMENSION	482(W) × 44(H) × 172(D) mm

- 900MHz 대역의 무선 마이크 시스템을 위한 외부 안테나 신호 분배기능
- RF 증폭기와 외부 확장 안테나의 옵션 장착 가능
- Spurious Interference의 영향을 최소화
- 매우 낮은 Inter-Modulation Distortion을 갖도록 설계
- External antenna signal distribution for 900MHz band wireless microphone systems
- Optional RF amplifier and external extension antenna available
- Minimize the effects of spurious interference
- Designed to have very low Inter-Modulation Distortion

SOUND REINFORCEMENT SYSTEM

DM32PRO	Digital Audio Mixer	70
MX-1204PS	Analog Audio Mixer	70
DSP48PRO	Professional Audio Processor	71
FBS4	High Speedback Suppression System	71
PA-EQ131/231	Graphic Equalizer	72
SP-9600	Sequence Power Distributor	72
DA-200/300/400/600	Professional Digital Power Amplifier	73
PN2S/4S6S	Stereo Power Amplifier	74
PN14S	Stereo Power Amplifier	75
PN88S	Professional Power Amplifier	75



DIGITAL AUDIO MIXER

DM32PRO



ANALOG AUDIO MIXER

MX-1204PS



SPECIFICATION	
DISPLAY	10.1" / 1280x800
TOUCH CONTROL	Capacitive touch
MASTER CPU	Samsung 4418 4-core Cortex™-A9
OPERATING SYSTEM	Linux
DSP	ADSP-21489 400Mhz
ANALOG INPUT	16CH (14MIC + 2Line)
DIGITAL INPUT	S/P DIF, optical fiber
DIGITAL OUTPUT	AES EBU
USB PLAYBACK	Play formats APE, FLAC, MP3, WAV
USB RECORDING	Support recording
ANALOG OUTPUT	L/R+6BUS+2AUX+Headphone(L/R)
SEX TO NOISE RATIO	-108dB no memory power
DYNAMIC RANGE	108dB
MAXIMUM IN/OUT LEVEL	18dBu (6.2Vrms) Balance
EFFECTOR	2 Effects
FEEDBACK SUPPRESSOR	16 channel feedback suppressor
OUTPUT DELAY	Output delay 1 second
ETHERNET	100M
POWER SOURCE	AC 100v-240v ; 50/60Hz 55W
WEIGHT	10.7 kg
DIMENSION	535(W) × 205(H) × 485(D) mm

SPECIFICATION	
FREQUENCY RESPONSE	20Hz~30kHz
T.H.D	< 0.01% (Channel to mix out)
CROSSTALK	Fader shutoff : > 85dB Mute shutoff : > 85dB Inter channel : > 82dB
HPF	75Hz, -12dB/oct
CMRR(MIC1kHz)	> 75dB
WEIGHT	7.7kg
DIMENSION	482(W) × 120(H) × 430(D) mm

- 10.1" 정전식 터치스크린 장착
- 해상도 : 1280x800
- 100mm 간격의 음량조절 볼륨 13개 적용
- USB 녹음 및 재생 기능 내장
- APE, FLAC, MP3 및 WAV 파일 재생 기능
- USB 재생시 노래 제목 표시 기능
- 14개의 채널별 DSP(digital signal processor) 기능
- Equipped with a 10.1" capacitive touchscreen
- Resolution: 1280x800
- 13 volume control knobs at 100mm intervals
- Built-in USB recording and playback function
- Ability to play APE, FLAC, MP3, and WAV files
- Song title display function when playing USB
- 14 channel-specific DSP (digital signal processor) functions

- 녹음 기능
- 2-그룹 스테레오 채널 입력
- 반응형 3 밴드, MF Sweep EQ
- 개별 팬텀 파워
- 내장 사운드 카드
- MP3 플레이어
- 9밴드 그래픽 EQ
- Recording
- 2-group stereo channel input
- Reactive 3-band, MF Sweep EQ
- Individual phantom power
- Built-in sound card
- MP3 Player
- 9-band graphic EQ

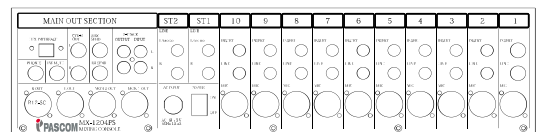
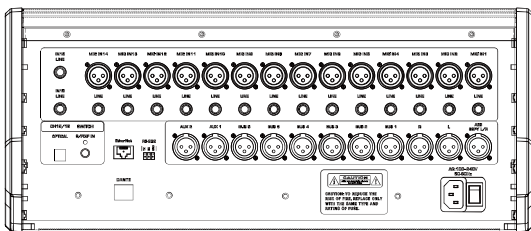

PROFESSIONAL AUDIO PROCESSOR

DSP48PRO



SPECIFICATION	
PROCESS	ADI Sharc 21489 450MHz
SYSTEM DELAY	2.1ms
AD / DA	24-bit 96KHz
INPUT	4 channels balanced
MAX INPUT LEVEL	20dBu / Line
DANET IN / OUT	4 * 4 channels optional
OUTPUT	8 channels balanced. Line level
FREQUENCY RESPONSE	20Hz ~ 20KHz (±0.5dB) / Line
THD+N	-93dB(OdBu, 1KHz, A-wt) /Line
GROUND NOISE	20Hz ~ 20KHz, A-wt, -93dBu
SNR	113dB(16dBu, 1KHz, A-wt) / Line
USB	Type A-B, free driver
RS232	Serial port communication
TCP / IP INTERFACE	Clip, lever, edit, mute
POWER SOURCE	AC 100 ~ 240V / 50,60Hz
WEIGHT	3.8kg
DIMENSION	483(W) × 44.5(H) × 265(D) mm

- 입 / 출력 : 4 IN / 8 OUT
- 입 / 출력 단자 : XLR
- 4채널의 Dante 네트워크 오디오 선택 기능
- 96KHz 샘플링 주파수, 24bit A/D와 D/A Converter 사용
- 15개 대역의 PEQ 입력과, 10개 대역의 PEQ 출력기능
- Butterworth/Bessel/Linkwitz-Riley 방식의 HPF 및 LPF, LSLV HSLV 기능
- ALL-PASS, 대역통과, 대역차단, 위상, Notch 필터, 3종류의 고역 통과 및 저역 통과 기능
- 3밴드 EQ 입력
- PC연결을 위한 USB 또는 TCP/IP, RS-232 컨넥터 지원
- 30개의 User Program Parameter 값 저장 기능
- 시스템버튼으로 비밀번호 설정하여 패널 기능 제어 LOCK 기능
- 시그널 입/출력 신호를 확인하기 위한 LED 표시기능
- 다양한 오디오 성능으로 무대 또는 Bar 및 기타 고급 사운드 시스템에 적합

- Input/Output: 4 IN/8 OUT
- Input/Output Terminals: XLR
- 4-channel Dante network audio selection function
- 96KHz sampling frequency, 24bit A/D and D/A converter used
- 15-band PEQ input and 10-band PEQ output function
- Butterworth/Bessel/Linkwitz-Riley HPF and LPF, LSLV HSLV Function
- All-pass, bandpass, bandstop, phase, and notch filters, with three types of high-pass and low-pass functions.
- 3-band EQ input
- Supports USB or TCP/IP, RS-232 connectors for PC connection
- Ability to store 30 User Program Parameter values
- Lock function to control panel functions by setting a password
- using the system button
- LED display function to check signal input/output signals
- Suitable for stage, bar, and other high-end sound systems with versatile audio performance.

HIGH SPEED BACK SUPPRESSION SYSTEM

FBS4



SPECIFICATION	
ACOUSTIC GAIN	-1dB or 11dB
LINE INPUT IMPEDANCE	15kΩ
LINE OUTPUT IMPEDANCE	300Ω
FREQUENCY RESPONSE	80Hz ~ 15KHz
S / N	82dB
POWER SOURCE	AC 220V / 50,60Hz
WEIGHT	3.5Kg
DIMENSION	482(W) × 44(H) × 260(D) mm

- 68개의 자동 필터 포인트로 하울링 방지 가능
- 출력 값 설정 기능으로 설정값 이상의 신호 자동 차단 기능
- 과입력으로 차단기능 동작후 정상입력시 자동 복구 기능
- It has 68 filter points which can be scanned automatically, and the automatic dynamic filter can prevent screaming.
- Anti-whistle start doesnot affect the sound quality.
- This machine hasthefunction of automatic pressure limit at critical point.
- In order to prevent the distortion or damage of equipment caused by signal overload, when the sound is strict.
- When the weight is too large, the anti-whistle suppression is accompanied by the pressure limit start to suppress part of the sound, which can prevent damage to the loudspeaker. Equipment.
- When the volume returns to normal, the pressure limit will slowly recover. (Normal use, pressure limit function does not start, does not affect any use)

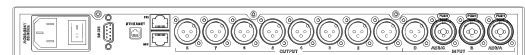
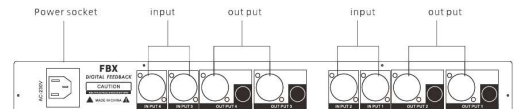

DSP48PRO

GRAPHIC EQUALIZER

PA-EQ131/231



SPECIFICATION	PA-EQ131	PA-EQ231
OCTAVE 31 BAND (20Hz~20kHz)	1/3 OCTAVE	
QUALITY FACTOR (CONSTANT Q)	30mV (Changeable by sensitivity controller in front)	
OUTPUT LEVEL / IMPEDANCE	+4dBu / 50Ω	
INPUT SENSITIVITY / IMPEDANCE	+4dBu / 20kΩ	
FREQUENCY RESPONSE	20Hz~20kHz	
T.H.D (30kHz WTD ON)	0.03%	
S/N (30kHz WTD ON)	90dB	
HPF (80Hz, -3dB)	-3dB	
DIMENSION	482(W)×44(H)×280(D)mm	482(W)×88(H)×430(D)mm

- 1채널 31밴드(PA-EQ131), 2채널 31밴드(PA-EQ231) 그래픽 이퀄라이저
- 초저역을 제거하는 HPF로 음의 명료도 향상 가능
- 입력과 출력에 전자 밸런스 회로 내장
- XLR, PIN JACK 입출력 단자
- EQ 볼륨의 부스트(+12dB) 또는 컷트(-12dB) 시 주파수 폭을 일정화
- 각 채널의 주파수를 CUT하는 스위치가 있어 마이크 하울링 제거 가능
- 1CH 31-band(PA-EQ131), 2CH 31-band(PA-EQ231) graphic equalizer
- Able to make sound clear by HPF
- Balance circuit embedded in input and output
- XLR, PIN JACK for in/out terminal
- Regularize the frequency when boost(+12dB) or cut(-12dB) the each channel's frequency
- Switch for cutting each channel's frequency enables to remove howling of the microphone

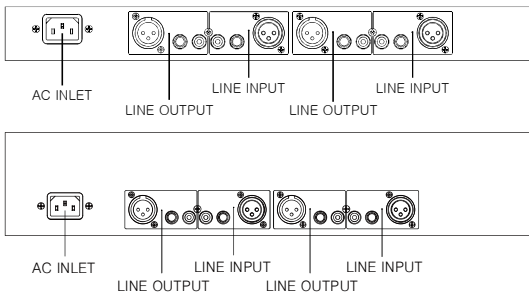

SEQUENCE POWER DISTRIBUTOR

SP-9600



SPECIFICATION	
CHANNEL	SWITCHED 8CH, UNSWITCHED 1CH
OUTPUT CAPACITY	AC 220V, 10A per channel
CONTACT TIME INTERVAL	ON TIME : 0.5sec ~ 4sec (setable) OFF TIME : 0.5sec ~ 4sec (setable)
LINK CONTROL	RS-485 ADDRESS (MAX 15 UNITS CONNECTABLE)
EXTERNAL OUTPUT	LAMP AC 12V/400mA, DC 24V/1.5A, AC 220V
CONTROL	SEQUENCE ON/OFF LAMP, ALL, REMOTE
POWER SOURCE	AC 220V/60Hz
POWER CONSUMPTION	10kW MAX
WEIGHT	10kg
DIMENSION	482(W) × 88(H) × 280(D) mm

- 원터치 방식의 8채널 순차 전원 스위치 선택
- 채널 별 모든 동작 상태를 기억하여 전원이 비정상적으로 OFF 되었을 경우 ON시에 자동으로 해당 채널을 자동 복구
- HOST LINK 및 CLIENT LINK 기능으로 15대의 장비를 연결하여 원격 제어 가능
- 비상용 장비 또는 기타 장비를 연결하여 원격 제어 가능
- 메인 전원의 전압 상태를 디스플레이하여 표시
- One-touch type switches for 8 channels
- Memorize the operation to recover automatically when the power is OFF in abnormal way
- Able to connect and control remotely 15 units by HOST LINK and CLIENT LINK
- Able to control emergency unit and other units remotely
- Indicate the voltage status of main power

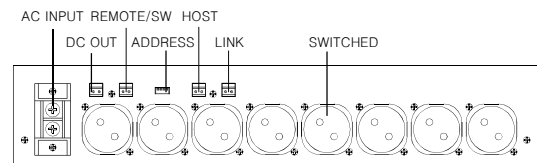

PROFESSIONAL DIGITAL POWER AMPLIFIER

DA-200/300/400/600/800



SPECIFICATION	DA-200	DA-300	DA-400	DA-600
OUT POWER (8Ω)	200W X 4	300W X 4	400W X 4	600W X 4
OUT POWER (4Ω)	400W X 4	500W X 4	600W X 4	1000W X 4
OUT POWER (bridge 8Ω)	600W X 4	900W X 4	1200W X 4	-----
OUTPUT CIRCUIT TYPE	CLASS D			
FREQUENCY RESPONSE	20Hz~20KHz			
T.H.D.(20Hz~20KHz 8Ω)	≤0.1%			
S/N	≥103dB			
DAMPING COEFFICIENT (8Ω)	> 400			
POWER SOURCE	AC 100 ~ 240V / 50,60Hz			
WEIGHT	6.1kg			
DIMENSION	482(W) × 45(H) × 350(D) mm			

- 1U 사이즈 4채널 파워 앰프
 - 개별 채널의 출력을 위한 2개의 D-Class 앰프 내장
 - 새틀라이트용 120Hz High Pass 필터, ON / OFF 스위치 내장
 - 서브우퍼용 120Hz Low Pass 필터, ON / OFF 스위치 내장
 - DC 검출, 고온, 과부하 및 단락 보호 회로 적용
 - 높은 댐핑 팩터와 낮은 왜곡률로 평탄한 소리 출력
 - 발란스 XLR 입력단자 적용
 - Speakon 잭 출력단자 적용
- 1U size 4-channel power amplifier
 - Built-in two D-Class amplifiers for individual channel output
 - 120Hz High Pass Filter for Satellite, Built-in ON/OFF Switch
 - 120Hz Low Pass Filter for Subwoofer, Built-in ON/OFF Switch
 - DC detection, high temperature, overload and short-circuit protection circuits applied
 - Flat sound output with high damping factor and low distortion
 - Balanced XLR input terminal applied
 - Speakon jack output terminal application

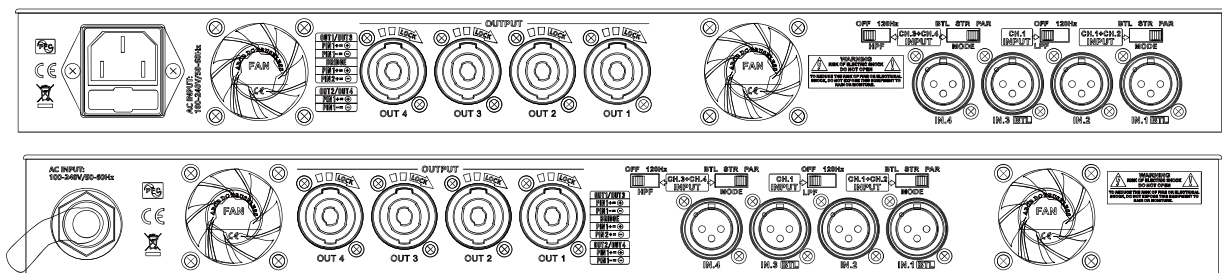

STEREO POWER AMPLIFIER

PN2S/4S/6S



SPECIFICATION	PN2S	PN4S	PN6S
OUTPUT POWER (8Ω)	2×200W	2×400W	2×600W
OUTPUT POWER (4Ω)	2×300W	2×700W	2×1050W
OUTPUT POWER (2Ω)	2×500W	2×1000W	2×1400W
OUTPUT POWER (BRIDGE,8Ω)	650W	1250W	1750W
OUTPUT POWER (BRIDGE,4Ω)	950W	1700W	2300W
FREQUENCY RESPONSE	15Hz~25kHz(+0/-1dB)		
T.H.D	< 0.03%		
S/N	> 102dB		
SLEW RATE	40V/μs		
DAMPING FACTOR	> 400:1		
INPUT SENSITIVITY	Selectable(0.77V/1.0V/1.44V)		
INPUT IMPEDANCE	10kΩ (Balanced to ground)		
POWER SOURCE	AC 220V / 60Hz		
WEIGHT	18.5kg	22.5kg	25kg
DIMENSION	482(W) × 88(H) × 440(D) mm		

- 2U의 컴팩트한 사이즈로 고출력 구현
- 노이즈 최소화를 위한 대전류 트로이달 트랜스 사용
- 과전류, 과열 보호 회로 내장
- LED를 통하여 기기의 동작 상태 확인 가능
- 히트싱크 온도에 따라 팬 속도 자동 조절
- Extreme power with compact 2U size
- Made with high-current troidan transformer for minimizing the noise
- Protection circuit embedded for overheat and over-current
- Able to check a status by LED
- Fan automatically controls its speed according to the temperature of heat sink

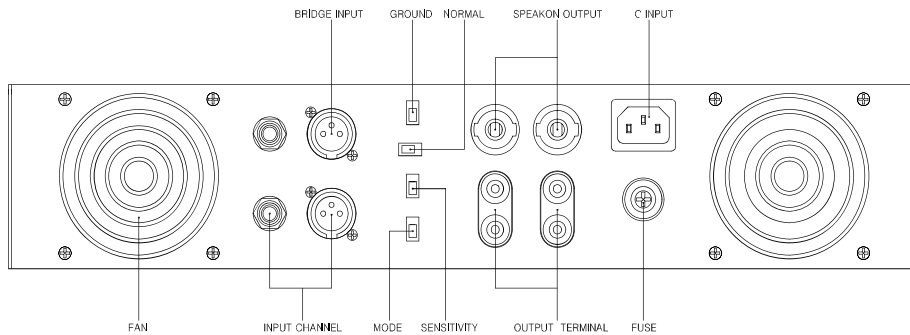

STEREO POWER AMPLIFIER

PN14S



SPECIFICATION	
RATED OUTPUT (8Ω)	2350W
RATED OUTPUT (4Ω)	4400W
RATED OUTPUT (2Ω)	7000W
RATED OUTPUT (4Ω, BRIDGE)	14000W
T.H.D	< 0.1%
FREQUENCY RESPONSE	23Hz~56kHz
INPUT IMPEDANCE	20kΩ
OUTPUT IMPEDANCE	30MΩ
WEIGHT	12kg
DIMENSION	482(W) × 88(H) × 343(D) mm

- 2U의 컴팩트한 사이즈로 고효율 구현
- 노이즈 최소화를 위한 대전류 트로이달 트랜스 사용
- 과전류, 과열 보호 회로 내장
- LED를 통하여 기기의 동작 상태 확인 가능
- 히트싱크 온도에 따라 팬 속도 자동 조절
- Extreme power with compact 2U size
- Made with high-current troidan transformer for minimizing the noise
- Protection circuit embedded for overheat and over-current
- Able to check a status by LED
- Fan automatically controls its speed according to the temperature of heat sink

PROFESSIONAL POWER AMPLIFIER

PN88S



SPECIFICATION	
CHANNEL	4CH
TOTAL OUTPUT POWER	8800W
PEAK OUTPUT VOLTAGE PER CHANNEL	141V
MAX OUTPUT CURRENT PER CHANNEL	35.5A
FREQUENCY RESPONSE	23Hz~56kHz
T.H.D (30kHz WTD ON)	0.1%
S/N (30kHz WTD ON)	> 112dBA
IMPEDANCE	20kΩ
OUTPUT IMPEDANCE	30MΩ
WEIGHT	12kg
DIMENSION	482(W) × 88(H) × 343(D) mm

- 2U의 컴팩트한 사이즈로 고효율 구현
- 노이즈 최소화를 위한 대전류 트로이달 트랜스 사용
- 과전류, 과열 보호 회로 내장
- LED를 통하여 기기의 동작 상태 확인 가능
- 히트싱크 온도에 따라 팬 속도 자동 조절
- Extreme power with compact 2U size
- Made with high-current troidan transformer for minimizing the noise
- Protection circuit embedded for overheat and over-current
- Able to check a status by LED
- Fan automatically controls its speed according to the temperature of heat sink

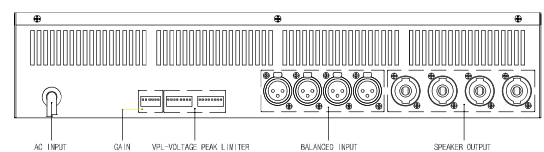
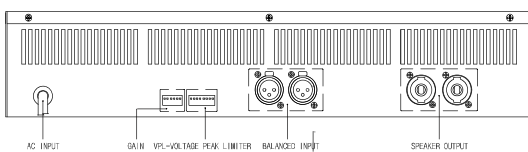

MIC / SPEAKER & ACCESSORIES

DM-980/990	Dinamic Microphone	78
PRM-01	Condensor Microphone	78
MS-1D	Microphone Stand(Desk Type)	78
MS-1F	Microphone Stand(Floor Type)	78
HY-08/10/12/15	Professional Loudspeaker	79
F-08/10/12/15	Professional Loudspeaker	79
F-200	Karaoke Speaker	80
SR-ST1	Speaker Stend	80
SR-SWB	Speaker Wall Braket	80
KWS-310(B/W)	Fashon Speaker	81
KFS-40/60/80(B/W)	Fashon Speaker	81
AS-01A	Ceiling Speaker	82
AS-101/102/103	Ceiling Speaker	82
AS-03A/06A/10A	Ceiling Speaker	83
AS-503/506	Ceiling Speaker	83
AS-03P	Ceiling Speaker	84
HS-20/30/50	Horn Speaker	84
KWS-03/10	Wall Speaker	85
KWS-03R/10R	Wall Speaker	85
PCS-10/20/30/40	Indoor Column Speaker	86
CS-410/420/430/440	Indoor Column Speaker	86
PCU-10/20/30/40	out door Column Speaker	87
CS-710/720/730/740	out door Column Speaker	87
PRS-30	Garden Speaker (Rock Speaker)	88
AAS-1000	All-in-one Active Speaker	88

DYNAMIC MICROPHONE

DM-980/990



SPECIFICATION	DM-980	DM-990
RATED POWER	600 ± 30%	
SENSITIVITY (0dB=1V / PA at 1KHz)	-70dB ± 3dB	-54dB ± 3dB
FREQUENCY RESPONSE	70Hz~12kHz	50Hz~15kHz
DIRECTIVITY	Momodirectivity	
MATERIAL	Zinc Alloy	
WEIGHT	290g	

CONDENSOR MICROPHONE

PRM-01



SPECIFICATION	
POWER	Phantom Power
USAGE	Conference, Lecture, Speech, Broadcast etc
INDICATOR	LED
CONNECTION	PC / AUDUO / AMPLIFIER etc
TYPE	Assemby

MICROPHONE STAND (DESK TYPE)

MS-1D



SPECIFICATION	
FREQUENCY RANGE	2.1kg

MICROPHONE STAND (FLOOR TYPE)

MS-1F



SPECIFICATION	
WEIGHT	2.2kg

PROFESSIONAL LOUDSPEAKER

HY-08/10/12/15



SPECIFICATION	HY-08	HY-10	HY-12	HY-15
RATED POWER	RMS:200W / MAX:400W	RMS:250W / MAX:500W	RMS:400W / MAX:800W	RMS:600W / MAX:1200W
DRIVERS (LF/HF)	Bass: 8-inch driver with 120mm magnet and 38mm voice coil Treble: 80mm magnet with 25mm voice coil	Bass: 10-inch driver with 156mm magnet and 65mm voice coil Treble: 90mm magnet with 34mm voice coil	Bass: 12-inch driver with 190mm magnet and 75mm voice coil Treble: 120mm magnet with 44mm voice coil	Bass: 15-inch driver with 190mm magnet and 75mm voice coil Treble: 120mm magnet with 44mm voice coil
FREQUENCY	65Hz~20kHz	50Hz~20kHz	50Hz~18kHz	35Hz~20kHz
SENSITIVITY	91dB	94dB	96dB	98dB
MAX SPL	113dB	116dB	118dB	120dB
DISPERATION	90°(H) × 50°(V)	70°(H) × 100°(V)	70°(H) × 100°(V)	70°(H) × 100°(V)
IMPEDANCE	8Ω			
CONNECTING	2 × NL4MP			
WEIGHT	8.5kg	16kg	21kg	32kg
DIMENSION	245(W) × 400(H) × 260(D) mm	300(W) × 535(H) × 340(D) mm	360(W) × 595(H) × 385(D) mm	410(W) × 680(H) × 440(D) mm

SR SPEAKER

F-8/10/12/15



SPECIFICATION	F-8	F-10	F-12	F-15
RATED POWER	RMS:200W / PEAK:800W	RMS:250W / PEAK:1000W	RMS:350W / PEAK:1400W	RMS:450W / PEAK:1800W
DRIVERS (LF/HF)	8" + 1"	10" + 1"	12" + 1"	15" + 3"
FREQUENCY	70Hz~20kHz	70Hz~20kHz	65Hz~18kHz	50Hz~20kHz
SENSITIVITY	94dB	96dB	97dB	99dB
MAX SPL	120dB	126dB	129dB	132dB
DISPERSION	90° × 50°	90° × 50°	80° × 50°	80° × 50°
IMPEDANCE	8Ω			
CONNECTING	2 × NL4			
WEIGHT	13kg	15kg	23kg	33kg
DIMENSION	299(W) × 269(H) × 435(D) mm	351(W) × 317(H) × 500(D) mm	398(W) × 365(H) × 571(D) mm	471(W) × 443(H) × 690(D) mm

KARAOKE SPEAKER

FS-200



SPECIFICATION	
RATED POWER	200W
IMPEDANCE	8Ω
SENSITIVITY	95dB
FREQUENCY	45Hz~18kHz
SOUND PRESSURE (1W/m)	99dB
WEIGHT	15kg
DIMENSION	525(W) × 290(H) × 320(D) mm

SPEAKER WALL BRACKET

SR-SWB



SPEAKER STAND (FLOOR TYPE)

SR-ST1



SPECIFICATION	
FREQUENCY RANGE	2kg

SPECIFICATION	
WEIGHT	4.3kg

FASHION SPEAKER (Black / White)

KWS-310(B/W)



SPECIFICATION	
RATED POWER	10W / 5W / 10W
IMPEDANCE	8Ω / 2kΩ / 10kΩ
FREQUENCY (-10dB)	90Hz~18kHz
SOUND PRESSURE(1W/m)	90dB
CASE	ABS
COLOR	Black / White
WEIGHT	600g
DIMENSION	104(W) × 160(H) × 100(D) mm

FASHION SPEAKER (Black / White)

KFS-40/60/80(B/W)



SPECIFICATION	KFS-40	KFS-60	KFS-80
RATED POWER	2.5W/5W/10W/20W/8Ω	3.75W/7.5W/15W/30W/8Ω	5W/10W/20W/40W/8Ω
IMPEDANCE	4kΩ/2kΩ/1kΩ/500Ω	2.6kΩ/1.3kΩ/660Ω/330Ω	2kΩ/1kΩ/500Ω/250Ω
FREQUENCY (-10dB)	70Hz~20kHz		
SOUND PRESSURE(1W/m)	89dB	90dB	91dB
CASE	ABS		
COLOR	White / Black		
WEIGHT	2.2kg	2.5kg	3.5kg
DIMENSION	170(W) × 215(H) × 150(D) mm	182(W) × 242(H) × 162(D) mm	215(W) × 284(H) × 190(D) mm

CEILING SPEAKER

AS-01A



SPECIFICATION	
RATED POWER	1W
IMPEDANCE	10kΩ
FREQUENCY (-10dB)	320Hz~15kHz
SOUND PRESSURE(1W/m)	90dB
CASE	ABS
COLOR	White
WEIGHT	224g
DIMENSION	120(W) × 120(H) × 45(D) mm

CEILING SPEAKER

AS-101/102/103



SPECIFICATION	AS-101	AS-102	AS-103
RATED POWER	1W	2W	3W
IMPEDANCE	10kΩ	5kΩ	3.3kΩ
FREQUENCY (-10dB)	320Hz~1.5kHz	150Hz~9kHz	110Hz~15kHz
SOUND PRESSURE(1W/m)	90dB	91dB	91dB
CASE		ABS	
COLOR		White	
WEIGHT	224g	235g	253g
DIMENSION		120(Front) × 45(D) mm	
HOLE SIZE		100Φ	

CEILING SPEAKER

AS-03A/06A/10A



SPECIFICATION	AS-03A	AS-06A	AS-10A
RATED POWER	3W / 1.5W	6W / 3W	10W / 50W
IMPEDANCE	3.3kΩ / 6.6kΩ	1.6kΩ / 3.3kΩ	1kΩ / 2kΩ
FREQUENCY (-10dB)	110Hz~15kHz		150Hz~17kHz
SOUND PRESSURE(1W/m)	92dB		
CASE	ABS		
COLOR	White		
WEIGHT	1.02kg	1.04kg	1.08kg
DIMENSION	227(Front)× 113(D) mm		
HOLE SIZE	190Φ		

CEILING SPEAKER

AS-503/506



SPECIFICATION	AS-503	AS-506
RATED POWER	3W/1.5W	6W/3W
IMPEDANCE	3.3kΩ/6.6kΩ	1.6kΩ/3.3kΩ
FREQUENCY (-10dB)	90Hz~16kHz	
SOUND PRESSURE(1W/m)	91dB	
CASE	ABS	
COLOR	White	
WEIGHT	440g	444g
DIMENSION	172(FRONT) × 65(D) mm	
HOLE SIZE	150Φ	

CEILING SPEAKER

AS-03P



SPECIFICATION	
RATED POWER	3W/1.5W
IMPEDANCE	3.3k Ω /6.6k Ω
FREQUENCY (-10dB)	110Hz~15kHz
SOUND PRESSURE(1W/m)	92dB
CASE	ABS
COLOR	White
WEIGHT	1.02kg
DIMENSION	300(FRONT) × 300(D) mm

HORN SPEAKER

HS-20/30/50



SPECIFICATION	HS-20	HS-30	HS-50
RATED POWER	20W	30W	50W
IMPEDANCE	500 Ω	333 Ω	200 Ω
FREQUENCY (-10dB)	205Hz~8kHz	380Hz~6.5kHz	380Hz~6.5kHz
SOUND PRESSURE(1W/m)	106dB		
CASE	Aluminum		
WEIGHT	2.16kg	2.35kg	2.55kg
DIMENSION	212(FRONT) × 229(D) mm	246(FRONT) × 280(D) mm	319(FRONT) × 336.4(D) mm

WALL SPEAKER

KWS-03/10



SPECIFICATION	KWS-03	KWS-10
RATED POWER	3 / 100V	10W /100V
IMPEDANCE	3.3kΩ/6.6kΩ	1kΩ/2kΩ
FREQUENCY (-10dB)	150Hz~17kHz	
SOUND PRESSURE(1W/m)	92dB	
CASE	ABS	
COLOR	White	
WEIGHT	1.15kg	1.3kg
DIMENSION	180(W) × 275(H) × 125(D) mm	

WALL SPEAKER

KWS-03R/10R



SPECIFICATION	KWS-03R	KWS-10R
RATED POWER	3 / 100V	10W /100V
IMPEDANCE	3.3kΩ/6.6kΩ	1kΩ/2kΩ
FREQUENCY (-10dB)	130Hz~17kHz	150Hz~17kHz
SOUND PRESSURE(1W/m)	92dB	
CASE	ABS	
COLOR	White	
WEIGHT	1.4kg	1.7kg
DIMENSION	240(W) × 350(H) × 100(D) mm	

INDOOR COLUMN SPEAKER

PCS-10/20/30/40



SPECIFICATION	PCS-10	PCS-20	PCS-30	PCS-40
RATED POWER	10W	20W	30W	40W
IMPEDANCE	2k Ω /1k Ω	1k Ω /500 Ω	660 Ω /330 Ω	500 Ω /250 Ω
FREQUENCY (-10dB)	180Hz~15kHz	180Hz~15kHz	180Hz~15kHz	180Hz~15kHz
SOUND PRESSURE(1W/m)	91dB	92dB	95dB	96dB
CASE	ABS			
COLOR	White			
WEIGHT	1.64kg	1.92kg	2.36kg	3.21kg
DIMENSION	150(W) × 253(H) × 110(D) mm			

INDOOR COLUMN SPEAKER

CS-410/420/430/440



SPECIFICATION	CS-410	CS-420	CS-430	CS-440
RATED POWER	10W	20W	30W	40W
IMPEDANCE	1k Ω /2k Ω	500 Ω /1k Ω	333 Ω /666 Ω	250 Ω /500 Ω
FREQUENCY (-10dB)	100Hz~15kHz	100Hz~15kHz	100Hz~15kHz	100Hz~15kHz
SOUND PRESSURE(1W/m)	89dB	90dB	92dB	93dB
CASE	Aluminum			
COLOR	White			
WEIGHT	1.6kg	2.5kg	3.3kg	3.9kg
DIMENSION	152(W) × 253(H) × 100(D) mm	152(W) × 373(H) × 100(D) mm	152(W) × 493(H) × 100(D) mm	152(W) × 613(H) × 100(D) mm

OUTDOOR COLUMN SPEAKER

PCU-10/20/30/40



SPECIFICATION	PCU-10	PCU-20	PCU-30	PCU-40
RATED POWER	10W	20W	30W	40W
IMPEDANCE	2k Ω /1k Ω	1k Ω /500 Ω	660 Ω /330 Ω	500 Ω /250 Ω
FREQUENCY (-10dB)	180Hz~15kHz	180Hz~15kHz	180Hz~15kHz	180Hz~15kHz
SOUND PRESSURE(1W/m)	91dB	92dB	95dB	96dB
CASE	Aluminum			
COLOR	Case : White / Grill : Black			
WEIGHT	1.64kg	2.64kg	3.5kg	4.2kg
DIMENSION	143(W) × 270(H) × 145(D) mm	143(W) × 370(H) × 145(D) mm	143(W) × 470(H) × 145(D) mm	143(W) × 570(H) × 145(D) mm

OUTDOOR COLUMN SPEAKER

CS-710/720/730/740



SPECIFICATION	CS-710	CS-720	CS-730	CS-740
RATED POWER	10W	20W	30W	40W
IMPEDANCE	1k Ω /2k Ω	500 Ω /1k Ω	333 Ω /666 Ω	250 Ω /500 Ω
FREQUENCY (-10dB)	100Hz~15kHz	100Hz~15kHz	100Hz~15kHz	100Hz~15kHz
SOUND PRESSURE(1W/m)	89dB	90dB	91dB	92dB
CASE	Aluminum			
COLOR	Brown			
WEIGHT	1.8kg	2.9kg	3.8kg	4.9kg
DIMENSION	152(W) × 258(H) × 125(D) mm	152(W) × 378(H) × 125(D) mm	152(W) × 498(H) × 125(D) mm	152(W) × 618(H) × 100(D) mm

GARDEN SPEAKER (ROCK SPEAKER)

PRS-30



SPECIFICATION	PRS-30
RATED POWER	30W
DRIVER	8" × 1,2.5" × 1
FREQUENCY RESPONSE	60Hz~14kHz
PEAK POWER	60W
SENSITIVITY (1m,1W)	88±2dB
MAX SPL (1m)	103±2dB
LINE VOLTAGE	70V / 100V
WEIGHT	8.5kg
DIMENSION	600(W) × 460(H) × 250(D) mm

ALL-IN-ONE ACTIVE SPEAKER

AAS-1000



SPECIFICATION	
Unit specifications	4x4" bass, 1x34mm horn tweeter
Rated impedance	4Ω
Rated power	250W (1000W, PEAK)
Characteristic sensitivity level	94dB (1m/1W)
Sound pressure level in the specified frequency band	115dB
Effective frequency range	80Hz-20kHz
Diffusion angle	horizontally : 120° / vertically : 40°
Circuit type	CLASS-D
Rated power (1kHz)	1x800W / 8Ω + 1x300W / 8Ω
Frequency response (1W/8Ω)	20Hz-25kHz (±0.5dB)
Intermodulation distortion	≤0.1% (20Hz-20kHz, half power)
Total harmonic distortion + noise	<0.1% (1kHz)
Phase response	≤±1.5° (20Hz-20kHz, 1W/8Ω)
Times to noise ratio	>110dB (A-weighted, rated power, 8Ω)
Input impedance	10KΩ (unbalanced), 20kΩ (balanced)
Damping factor (1kHz/8Ω)	800
Input sensitivity (1kHz/8Ω)	1V
Audio input interface (INPUT)	1 XLR (Canon) female socket
Audio output interface (LINK)	1 XLR (Canon) male connector
Power Source	AC 220V ~ 50/60Hz
Unit specifications	1x15"
Rated impedance	8Ω
Rated power	500W (2000W, PEAK)
Characteristic sensitivity level	102dB (1m/1W)
Sound pressure level in specified frequency band	126dB
Effective frequency range	40Hz-500Hz
Weight	43.6Kg
DIMENSION	Minimum:595(W) × 1820(H) × 600(D) mm Maximum:595(W) × 2170(H) × 600(D) mm

RACK CABINER

AR-Series	Aluminum Rack	90
CR-Series	Condensor Microphone	90

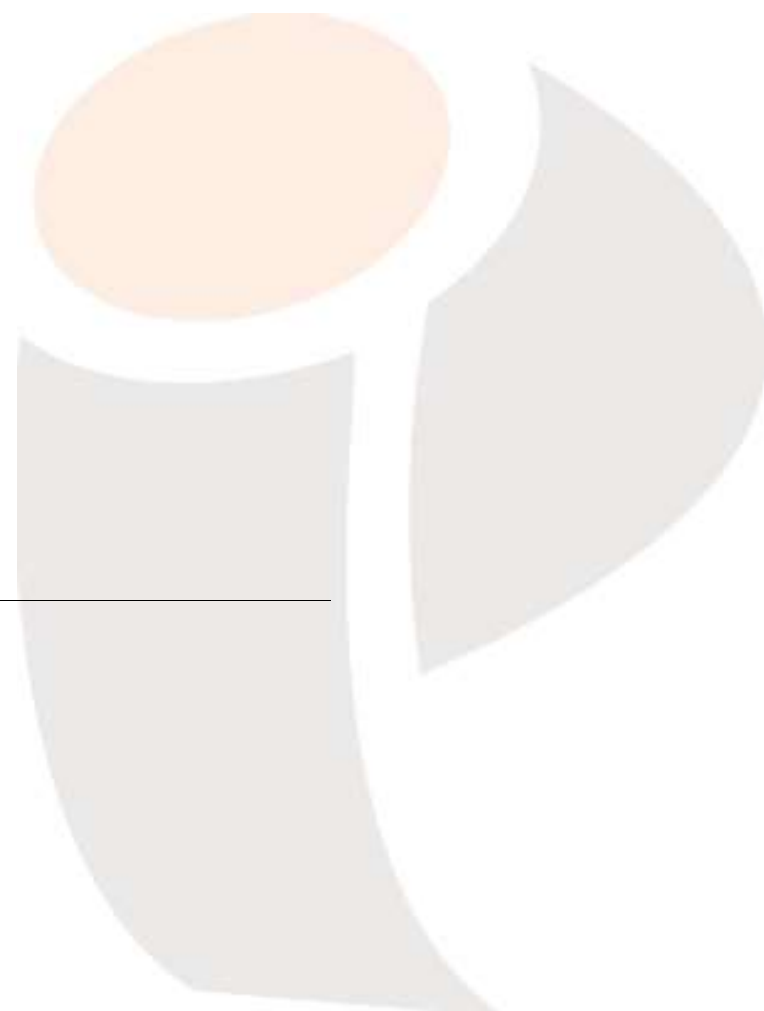

ALUMINUM RACK

AR



SPECIFICATION	DIMENSION (W × H × D)
AR-9U	600 × 600 × 600/650/750
AR-14U	600 × 800 × 600/650/750
AR-18U	600 × 1000 × 600/650/750
AR-23U	600 × 1200 × 600/650/750
AR-27U	600 × 1400 × 600/650/750
AR-32U	600 × 1600 × 600/650/750
AR-36U	600 × 1800 × 600/650/750
AR-41U	600 × 2000 × 600/650/750
AR-45U	600 × 2200 × 600/650/750

STEEL RACK

CR



SPECIFICATION	DIMENSION (W × H × D)
CR-9U	587 × 524 × 587
CR-11U	587 × 613 × 587
CR-15U	587 × 885 × 587
CR-21U	587 × 1152 × 587
CR-23U	587 × 1241 × 587
CR-27U	587 × 1428 × 587
CR-33U	587 × 1685 × 587
CR-39U	587 × 1952 × 587
CR-40U	587 × 2000 × 587

APPLICATION

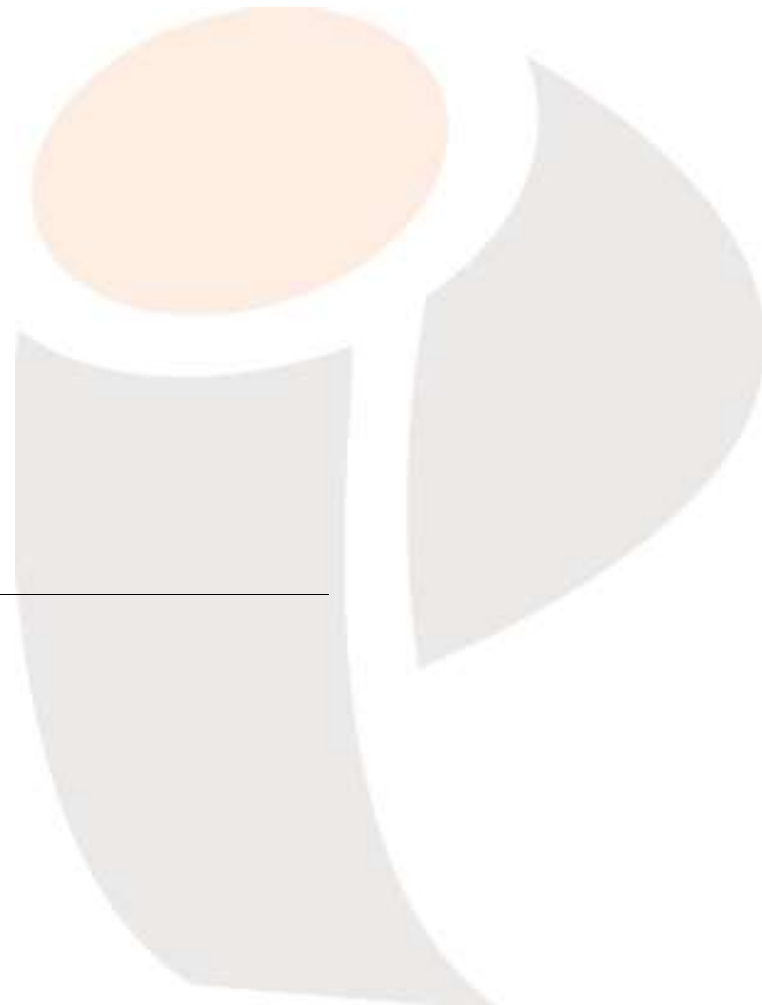

EMERGENCY EXCHANGER

PEX-4

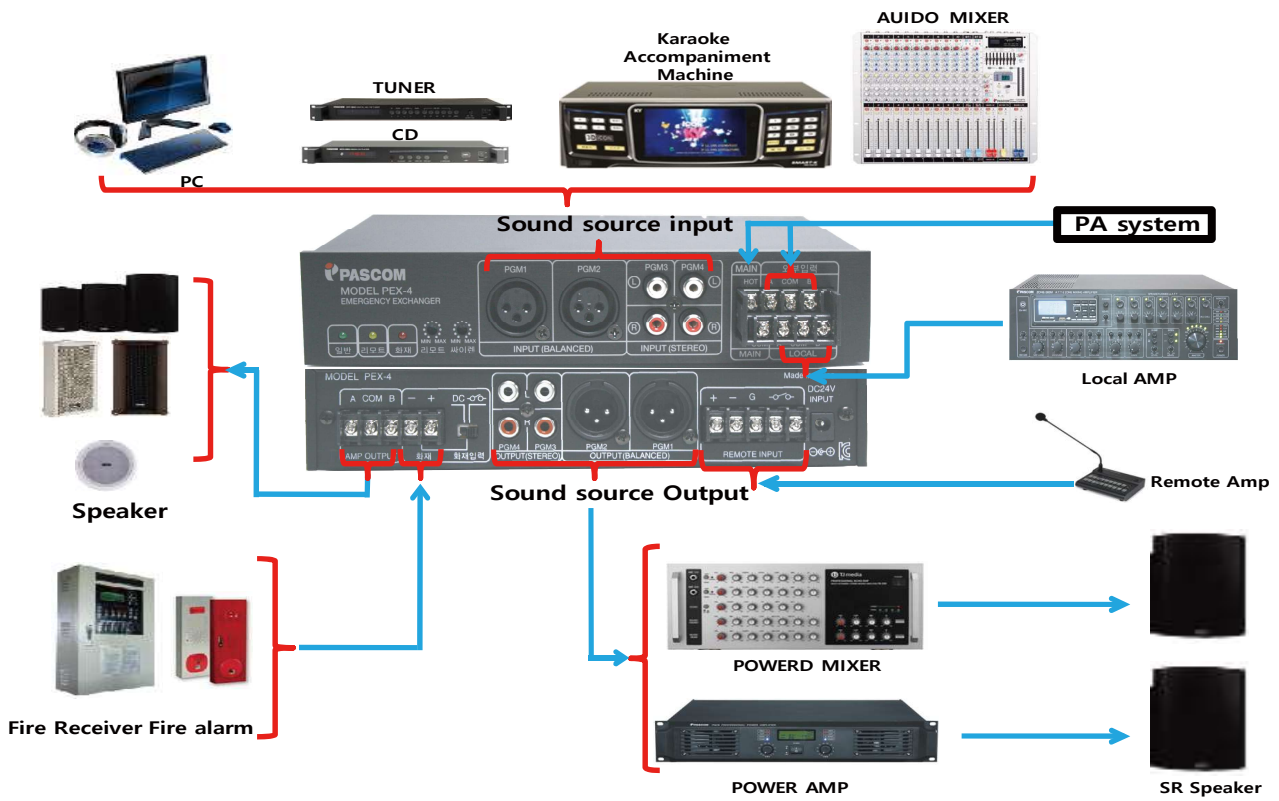

MULTI PA COMBINATION AMPLIFIER

PANDORA-1D/2D/3D

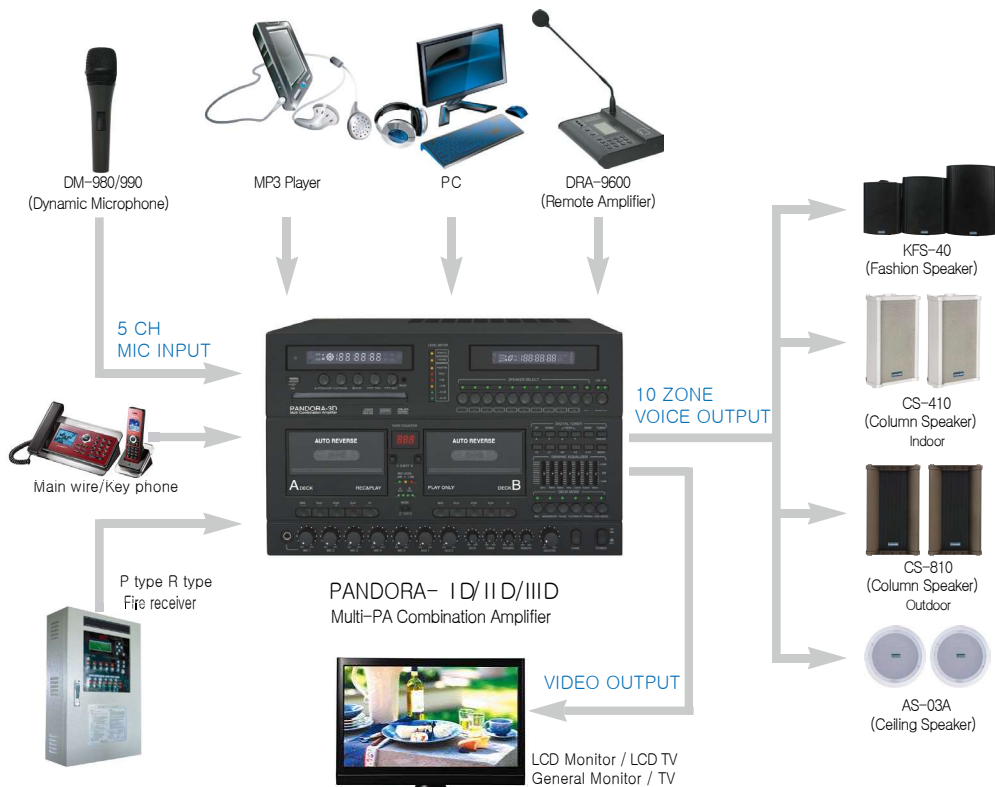

A.T.T 6 ZONE MIXING AMPLIFIER

ZONE-120M/240M/360M/480M/600M



MULTI COMBINATION AMPLIFIER

PCR-70D/130D

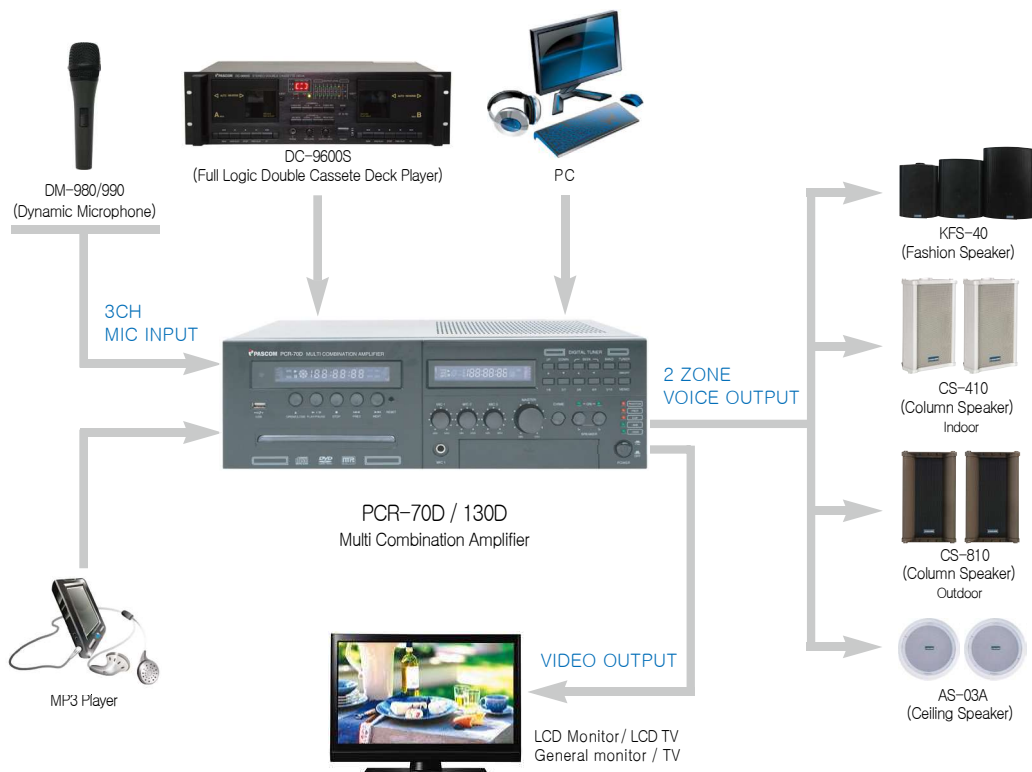

PUBLIC ADDRESS MIXING AMPLIFIER

PMA-60M/120M/240M

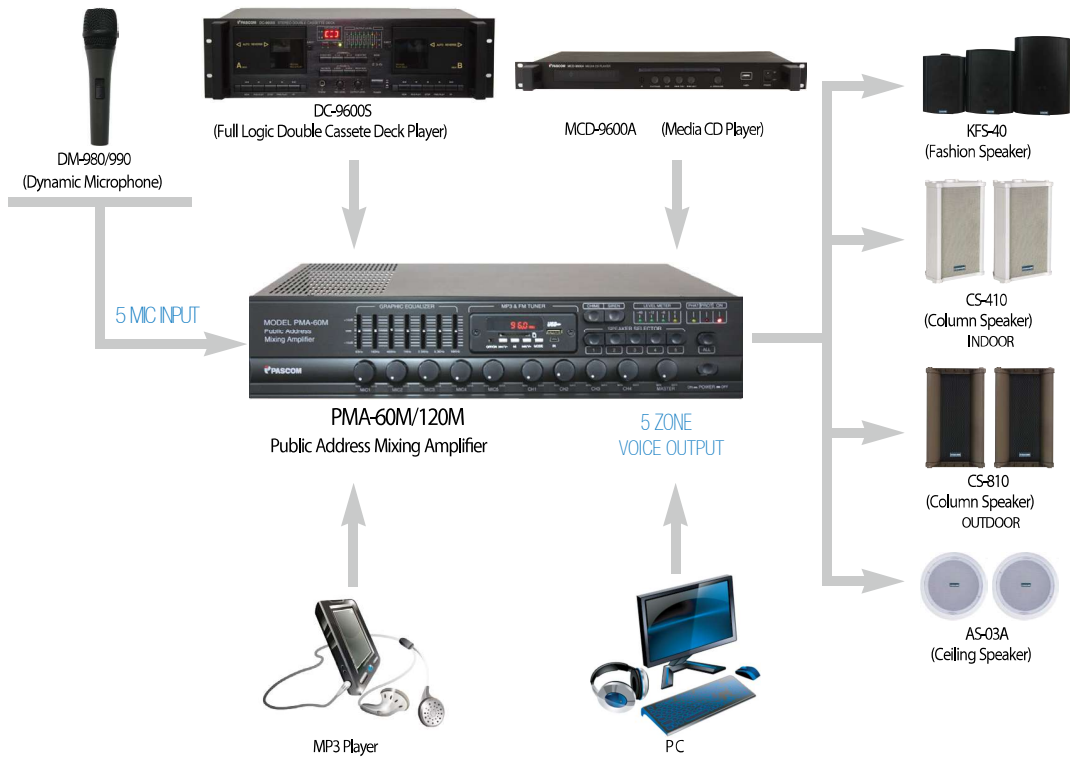

STEREO MIXING AMPLIFIER

MUSE-602



DIAGRAM

ANALOG SYSTEM

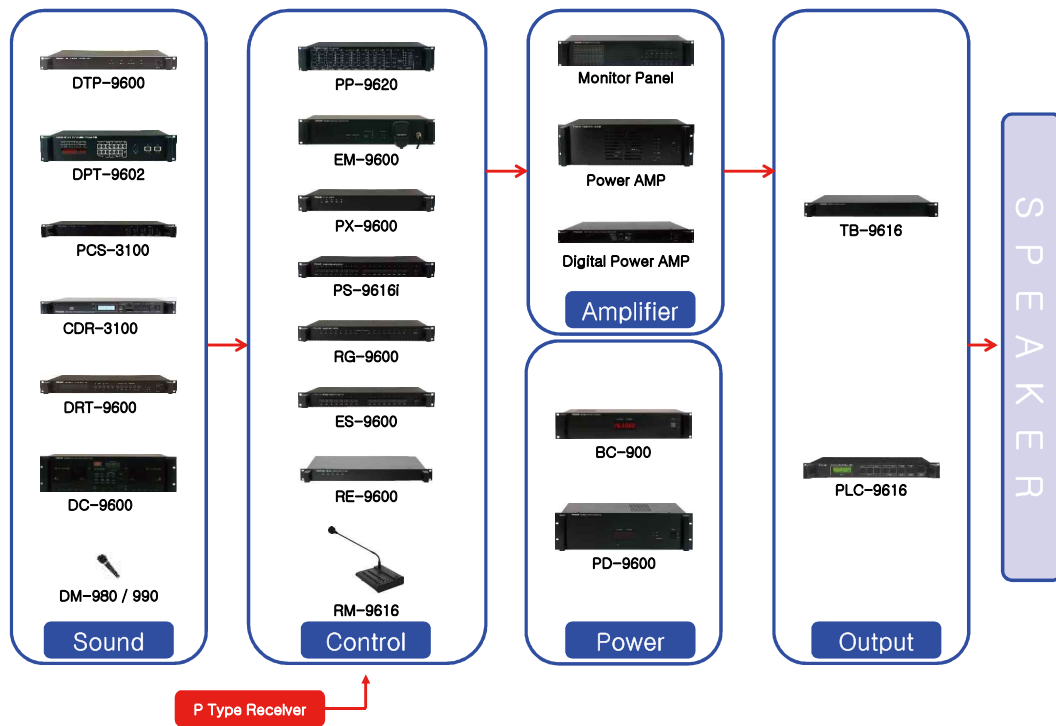

DIAGRAM

DIGITAL RX-TX SYSTEM

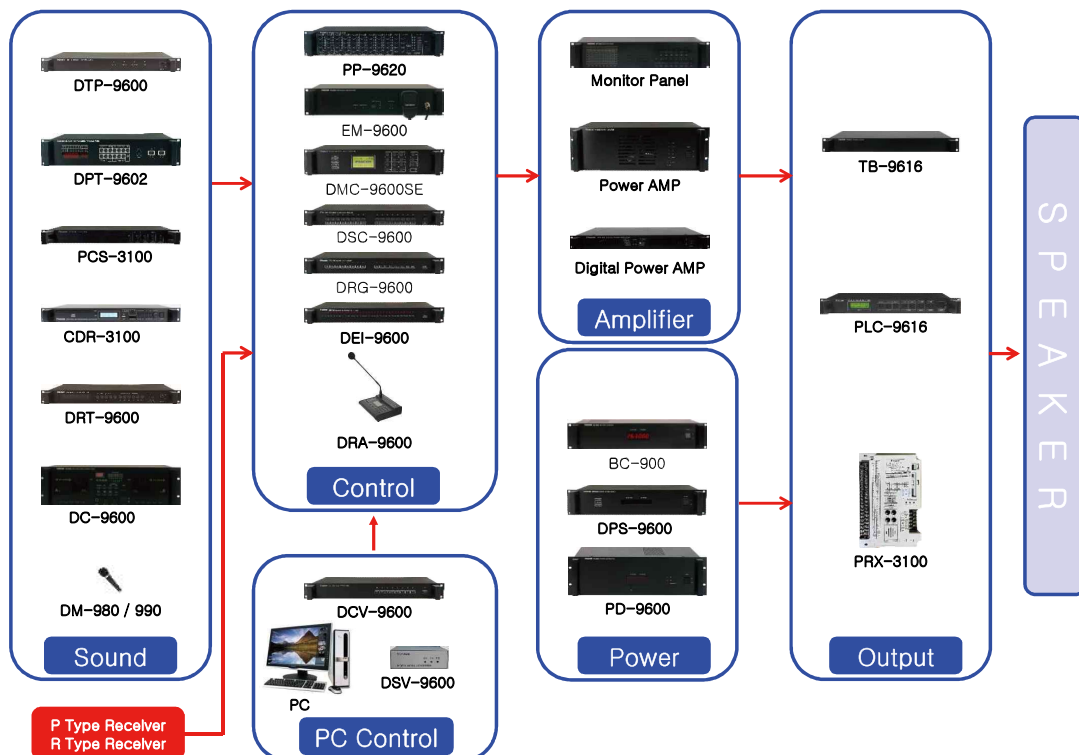

DIAGRAM

UNIFIED SYSTEM

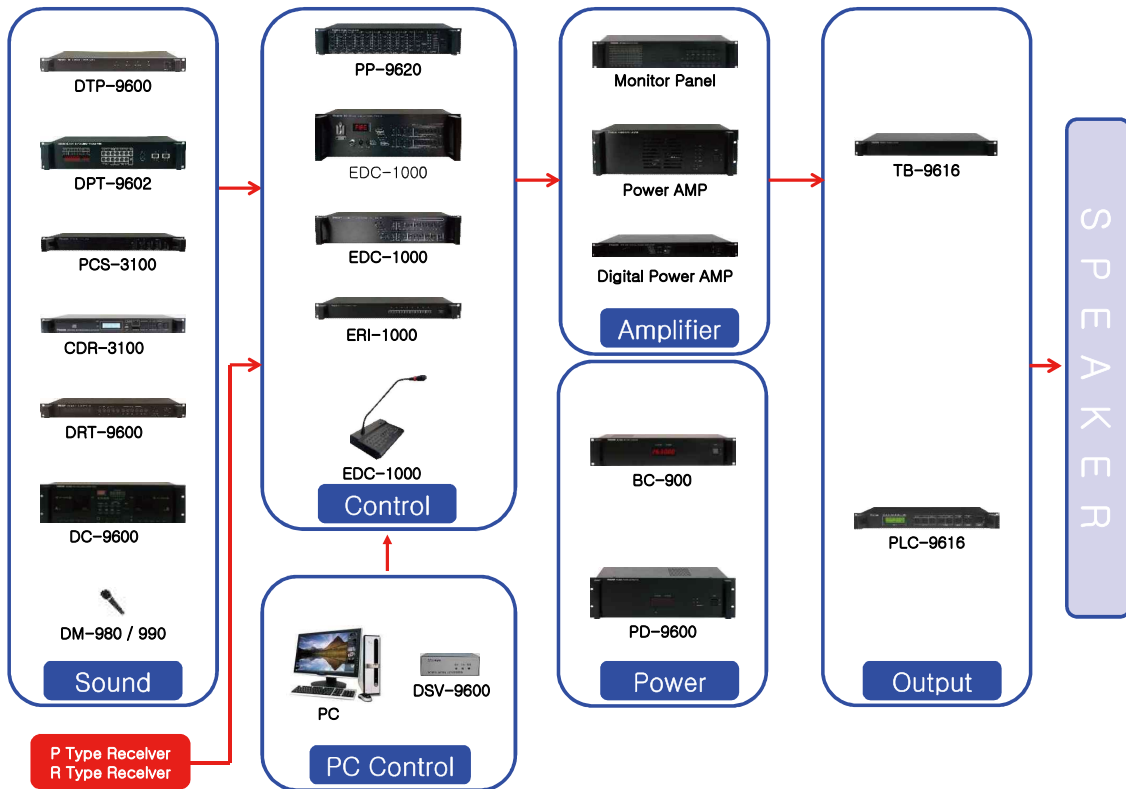

DIAGRAM

DIVERSIFIED SYSTEM

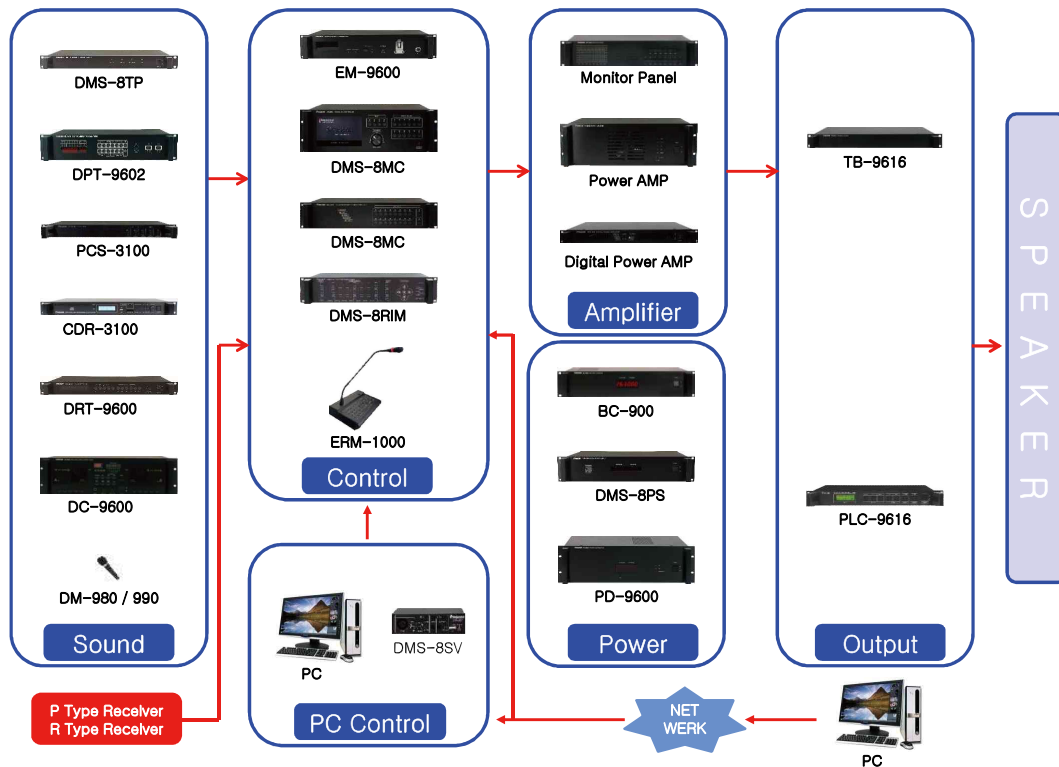



Commercial/Professional Audio

경기도 광주시 초월읍 경충대로 1333-32

1333-32, Gyeongchung-daero, Chowol-eup, Gwangju-si, Gyeonggi-do, Korea

Tel +82 31 733 1060 | Fax +82 31 733 1059 | www.ipascom.com

E-mail 국내영업부 : pmt@ipascom.com | Overseas Sales Dept : osam@ipascom.com